



**FITTING INSTRUCTIONS FOR TH0031 TRANSPORT HOOKS  
TO FIT HONDA CBR1000RR-R & SP 2020-**



**This kit contains the items pictured and labelled over page.  
Some parts may be shown for clarity of instructions only.  
Do not proceed until you are sure all parts are present.  
Please read all instructions before proceeding.**

**IF IN ANY DOUBT WHEN FITTING OUR PRODUCTS, CONSULT ONE OF OUR DEALERS  
OR HAVE FITTED BY A QUALIFIED TECHNICIAN.**

Please note that the way the kit is packed does not necessarily represent the way of mounting to the bike.

In the event of rubber washers being used to hold components onto bolts, these rubber washers can be thrown away.

**DIGITAL COPIES OF THESE INSTRUCTIONS ARE AVAILABLE FROM  
[WWW.RG-RACING.COM](http://WWW.RG-RACING.COM)**



<b>TOOLS REQUIRED</b>	<b>GENERAL TORQUE SETTINGS</b>
<ul style="list-style-type: none"> <li>Set of metric Allen keys to include 5MM.</li> </ul>	<p>M4 BOLT = 8Nm                      M5 BOLT = 12Nm                      M6 BOLT = 15Nm                      M8 BOLT = 20Nm                      M10 BOLT = 40Nm                      M12 BOLT = 40Nm</p>

**LEGEND**

<b>ITEM No.</b>	<b>DESCRIPTION</b>	<b>QTY</b>
ITEM 1	SMW0178 TIE DOWN HOOK	2
ITEM 2	M8 X 1.25 X 20MM COUNTERSUNK BOLT	4
ITEM 3	M8 X 1.25 X 25MM COUNTERSUNK BOLT	2

**ASSEMBLY DIAGRAM**

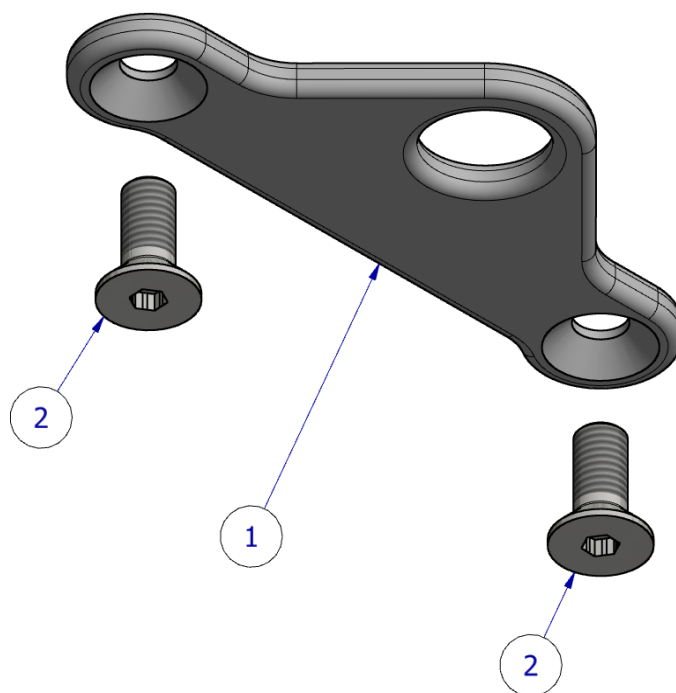



## **FITTING INSTRUCTIONS**

### **For both sides**

- Remove the original footrest brackets from the motorcycle.
- Offer the left-hand side tie down hook (**item 1**) into position and secure in position using the two M8 countersunk bolts (**item 2**) through both holes as shown in the assembly diagram.
- Tighten both bolts to the recommended torque.
- Check the tightness of all bolts regularly.

### **Right hand side (if fitting the R&G Exhaust hanger bracket)**

- Remove the original footrest bracket on the right-hand side of the motorcycle.
- Offer up the exhaust hanger and then the tie down hook plate will be placed on the outside of the hanger using the two M8x25mm countersunk bolts (**item 3**) to secure.
- Tighten both bolts to the recommended torque.
- Check the tightness of all bolts regularly.

ISSUE 2 19/01/2021 (DM)

### CONSUMER NOTICE

The catalogue description and any exhibition of samples are only broad indications of the Products and R&G may make design changes which do not diminish their performance or visual appeal and supplying them in such state shall conform to the order. The Buyer acknowledges no representation or warranty (other than as to title) has been given or will apply to the Products other than those in R&G's order or confirmation and the Buyer confirms it has chosen the Products as being of merchantable quality and suitable for its particular purposes. Where R&G fits the Products or undertakes other services it shall exercise reasonable skill and care and rectify any fault free of charge unless the workmanship has been disturbed. The Buyer is responsible for ensuring that the warranty on the motorcycle is not affected by the fitting of the Products. On return of any defective Products R&G shall at its option either supply a replacement or refund the purchase money but shall not be liable if the Products have been modified or used or maintained otherwise than in accordance with R&G's or manufacturer's instructions and good engineering practice or if the defect arises from accident or neglect. Other than identified above and subject to R&G not limiting its liability for causing death and personal injury, it shall not be liable for indirect or consequential loss and otherwise its liability shall be limited to the amounts paid by the Buyer for the Products or the fitting or service concerned. These terms do not affect the Buyer's statutory rights.

### **R&G RACING RETURNS POLICY (NON-FAULTY GOODS)**

Returns must be pre-authorized (if not pre-authorized the return will be rejected). Goods may only be returned direct to us if they were purchased direct from us (customer must prove if necessary). Otherwise to be returned to original vendor. Goods must be in re-sellable condition, in the opinion of R&G Racing. All returns are subject to a 25% restocking and handling fee (25% of the gross value exc. P&P - at the prevailing price at time of purchase). The customer must pay any and all carriage charges. No returns of discontinued products, unless within 14 days of purchase. This policy does not affect your statutory rights and does not refer to faulty goods.

R&G

Unit 1, Shelley's Lane, East Worldham, Alton, Hampshire, GU34 3AQ

Tel: +44 (0)1420 89007 Fax: +44 (0)1420 87301 [www.rg-racing.com](http://www.rg-racing.com) Email: [info@rg-racing.com](mailto:info@rg-racing.com)



**NOTICE DE MONTAGE POUR TH0031 CROCHETS D'ARRIMAGE  
POUR HONDA CBR1000RR-R & SP 2020-**



**CE KIT CONTIENT LES ARTICLES ILLUSTRÉS ET ÉTIQUETES SUR LA PAGE.**

CERTAINES PARTIES PEUVENT ÊTRE PRÉSENTES UNIQUEMENT POUR LA CLARTÉ DES INSTRUCTIONS.

NE PAS PROCÉDER AU MONTAGE TANT QUE VOUS N'ÊTES PAS SÛR QUE TOUTES LES PIÈCES SOIENT PRÉSENTES.

**VEUILLEZ LIRE TOUTES LES INSTRUCTIONS AVANT DE CONTINUER.**

**EN CAS DE DOUTE LORS DU MONTAGE DE NOS PRODUITS, CONSULTEZ UN DE NOS REVENDEURS OU FAITES APPEL À UN TECHNICIEN QUALIFIÉ.**

VEUILLEZ NOTER QUE LA FAÇON DONT LE KIT EST EMBALLÉ NE REPRÉSENTE PAS NECESSAIREMENT LA MANIÈRE DE LE MONTER SUR LA MOTO.

SI DES RONDELLES EN CAOUTCHOUC SONT UTILISÉES POUR MAINTENIR LES COMPOSANTS SUR LES BOULONS, ELLES PEUVENT ÊTRE JETÉES.

**NOTICE DISPONIBLE AU TÉLÉCHARGEMENT SUR : [WWW.RG-RACING.COM](http://WWW.RG-RACING.COM)**

R&G

Unit 1, Shelley's Lane, East Worldham, Alton, Hampshire, GU34 3AQ

Tel: +44 (0)1420 89007 Fax: +44 (0)1420 87301 [www.rg-racing.com](http://www.rg-racing.com) Email: [info@rg-racing.com](mailto:info@rg-racing.com)



<b>OUTILS REQUIS</b>	<b>GENERAL TORQUE SETTINGS</b>
<ul style="list-style-type: none"> <li>• Clés Allen 5mm.</li> </ul>	M4 BOULON = 8Nm M5 BOULON = 12Nm M6 BOULON = 15Nm M8 BOULON = 20Nm M10 BOULON = 40Nm M12 BOULON = 40Nm

### **LÉGENDE**

<b>ARTICLE No.</b>	<b>DESCRIPTION</b>	<b>QTÉ</b>
ARTICLE 1	SMW0178 CROCHETS D'ARRIMAGE	2
ARTICLE 2	M8 X 1.25 X 20MM BOULON	4
ARTICLE 3	M8 X 1.25 X 25MM BOULON	2

### **SCHÉMA D'ENSEMBLE**

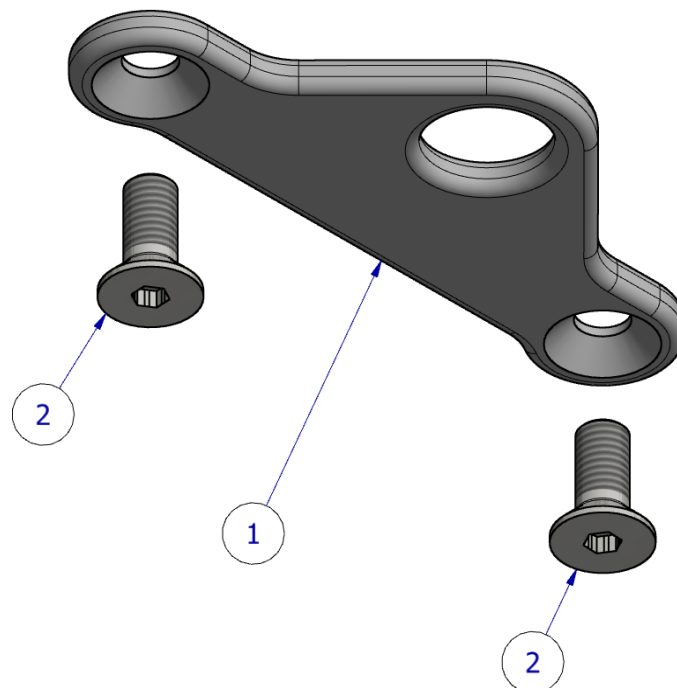

R&amp;G

Unit 1, Shelley's Lane, East Worldham, Alton, Hampshire, GU34 3AQ

Tel: +44 (0)1420 89007 Fax: +44 (0)1420 87301 [www.rg-racing.com](http://www.rg-racing.com) Email: [info@rg-racing.com](mailto:info@rg-racing.com)



## **NOTICE DE MONTAGE**

### **Pour les 2 côtés**

- Retirez les supports de repose-pieds d'origine de la moto.
- Présentez le crochet d'arrimage du côté gauche (article 1) en place et fixez-le en place à l'aide des deux boulons fraisés M8 (article 2) à travers les deux trous comme indiqué sur le schéma d'assemblage.
- Serrez les deux boulons au couple recommandé.
- Vérifiez régulièrement le serrage de tous les boulons.

### **Côté droit (Si vous Montez le support d'échappement R&G)**

- Retirez le support de repose-pied d'origine du côté droit de la moto.
- Présentez le support d'échappement puis la plaque du crochet d'arrimage sera placée à l'extérieur du crochet à l'aide des deux boulons fraisés M8x25mm (article 3) pour fixer.
- Serrez les deux boulons au couple recommandé.
- Vérifiez régulièrement le serrage de tous les boulons.

ISSUE 2 19/01/2021 (DM)

R&G

Unit 1, Shelley's Lane, East Worldham, Alton, Hampshire, GU34 3AQ

Tel: +44 (0)1420 89007 Fax: +44 (0)1420 87301 [www.rg-racing.com](http://www.rg-racing.com) Email: [info@rg-racing.com](mailto:info@rg-racing.com)