



**FITTING INSTRUCTIONS FOR TG0019 CHAIN & SPROCKET GUARD –
UNIVERSAL FITMENT**



This kit contains the items pictured and labelled over the page.

Some parts may be shown for clarity of instructions only.

Do not proceed until you are sure all parts are present.

Please read all instructions before proceeding.

**IF IN ANY DOUBT WHEN FITTING OUR PRODUCTS, CONSULT ONE OF OUR DEALERS
OR HAVE FITTED BY A QUALIFIED TECHNICIAN.**

Please note that the way the kit is packed does not necessarily represent the way of mounting to the bike.

In the event of rubber washers being used to hold components onto bolts, these rubber washers can be thrown away.

DIGITAL COPIES OF THESE INSTRUCTIONS ARE AVAILABLE FROM

WWW.RG-RACING.COM

R&G

Unit 1, Shelley's Lane, East Worldham, Alton, Hampshire, GU34 3AQ

Tel: +44 (0)1420 89007 Fax: +44 (0)1420 87301 www.rg-racing.com Email: info@rg-racing.com



<u>TOOLS REQUIRED</u>	<u>GENERAL TORQUE SETTINGS</u>
<ul style="list-style-type: none"> • 5MM DRILL BIT + DRILL • M6 x 1.00 TAP + TAP WRENCH <ul style="list-style-type: none"> • MARKER • PUNCH • 4mm & 5mm HEX KEYS 	M4 BOLT = 8Nm M5 BOLT = 12Nm M6 BOLT = 15Nm M8 BOLT = 20Nm M10 BOLT = 40Nm M12 BOLT = 40Nm

LEGEND

ITEM No.	DESCRIPTION	QTY
ITEM 1	MTG0019 CHAIN & SPROCKET GUARD	1
ITEM 2	M0614 MOUNT BLOCK	1
ITEM 3	M6x25MM CAP HEAD BOLT	2
ITEM 4	M6x15MM COUNTERSUNK BOLTS	2
ITEM 5	S1283 M6 COMPRESSION SLEEVE	1
ITEM 6	S1284 M8 COMPRESSION SLEEVE	1
ITEM 7	M10x19MM O/D WASHER	1
ITEM 8	M10 ANTI-ROTATION WASHER	1
ITEM 9	M6x25mm BUTTON HEAD BOLT	1
ITEM 10	M8x25mm BUTTON HEAD BOLT	1
ITEM 11	M10x25mm BUTTON HEAD BOLT	1

FITTING INSTRUCTIONS

THE INSTRUCTIONS BELOW DETAIL TWO SEPARATE FITTING OPTIONS. CHOOSE WHICH IS MOST SUITABLE FOR YOUR BIKE.

- For all fitting options, when positioning the Chain and Sprocket guard, ensure that:
 - The lower chain and sprocket area are covered.
 - The flat rear section of the Chain & Sprocket guard should cover the lower section of the sprocket.
 - The Chain and sprocket guard should be placed in parallel with the chain where it cannot come into contact with any moving components of the motorcycle. Consider any vertical or lateral movement of the chain and wheel assembly when placing the Chain & Sprocket guard.
 - Where bikes are fitted with a lower boss for aftermarket Cotton Reels for use with a paddock stand. Where applicable, the mount block (**item 2**) can be placed over this giving greater flexibility when fitting, in this instance, fit the Cotton Reel to help position the block as shown in the example on page 3.
 - See example of the intended coverage below:

R&G

Unit 1, Shelley's Lane, East Worldham, Alton, Hampshire, GU34 3AQ

Tel: +44 (0)1420 89007 Fax: +44 (0)1420 87301 www.rg-racing.com Email: info@rg-racing.com



INTENDED COVERAGE

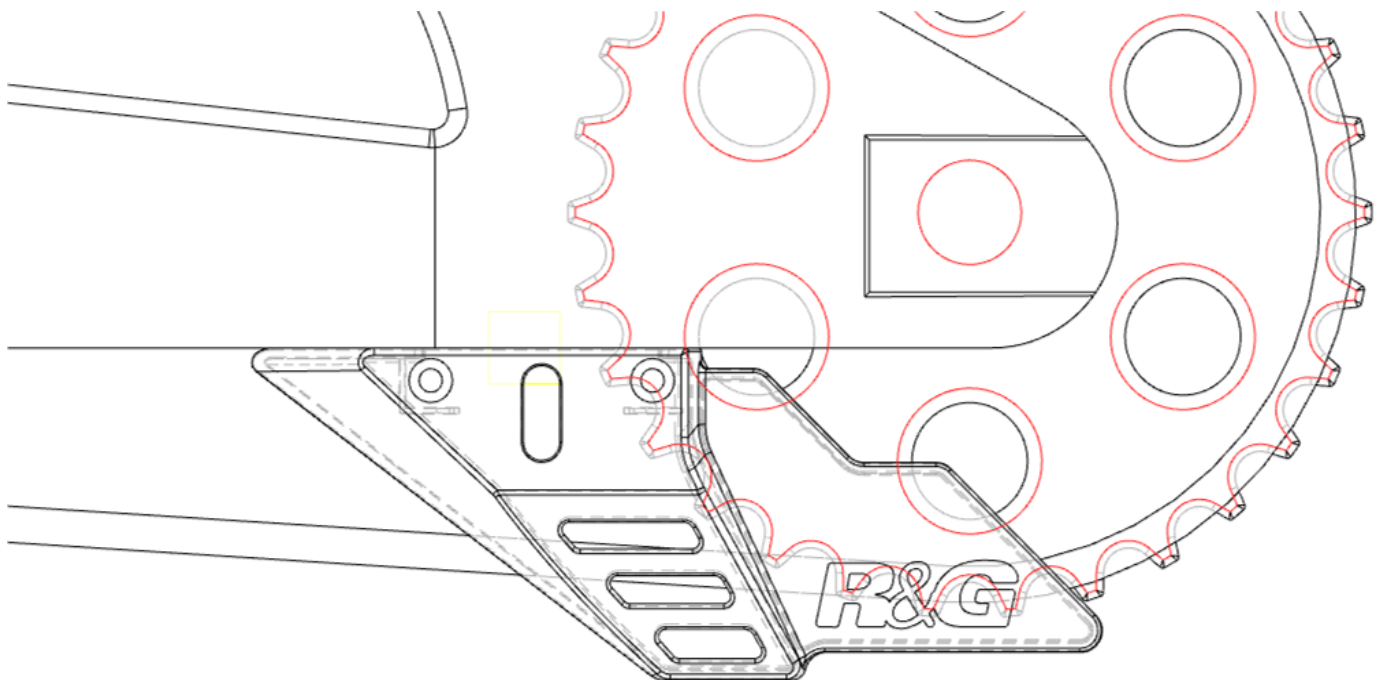

ASSEMBLY DIAGRAM 1

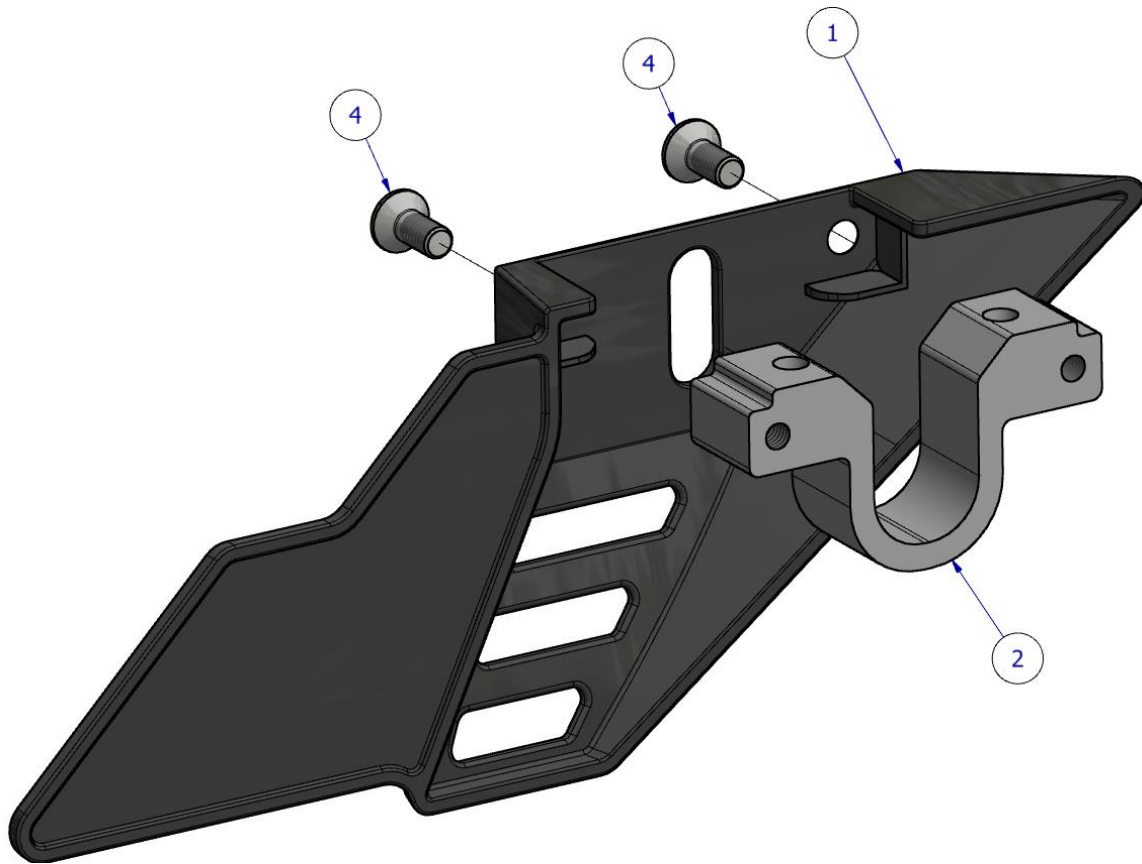

R&G



ASSEMBLY DIAGRAM 2

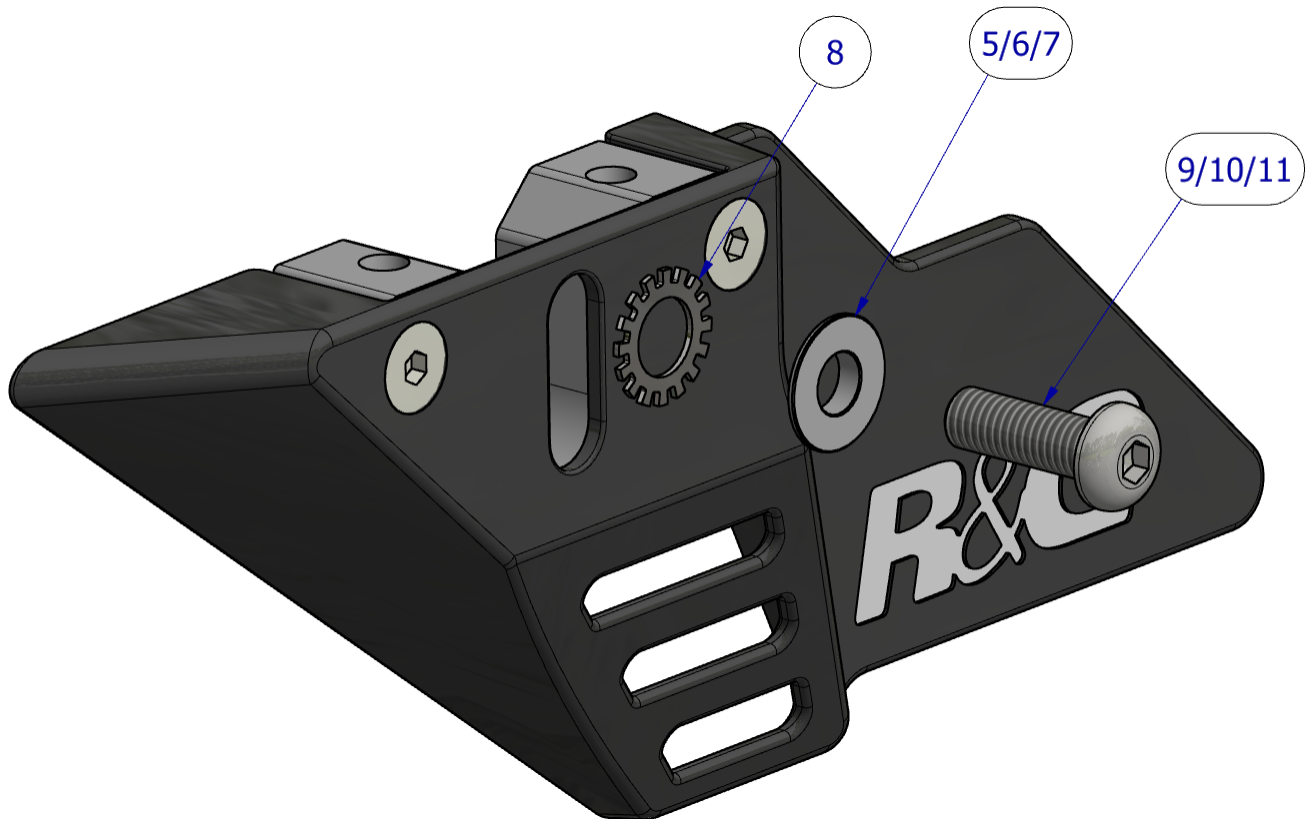

If fitting using the OEM Cotton Reel mount (Non-Drilled fitment)

- On some motorcycles, it is possible to fit the chain and sprocket guard using the lower boss on the swingarm for Cotton Reel mount without modification to the swingarm.
- Assemble the Chain & Sprocket guard according to **Assembly diagram 1** above by securing the aluminium Mount block (**M0614 - item 2**) to the Chain and sprocket Guard (**item 1**) using the countersunk bolts (**item 4**) tightened to the recommended torque.
- Next, referring to the legend, use the corresponding bolt and compression sleeve size suited to your bike in conjunction with the M10 anti-rotation washer (**item 8**) to affix the assembly in place as shown in **Assembly diagram 2**, ensuring the M10 anti rotation washer (**item 8**) sits against the plastic chain & sprocket guard (this washer will 'bed in' to the guard to prevent movement when riding).
- Tighten the bolt to the recommended torque and check the guard is secure.
- If fitting in conjunction with R&G Cotton Reels, proceed to fit in the same way using the Cotton Reel bolt in place of the bolt included with this kit, with the Cotton Reel on the outside of the compression sleeve (**Item 5, 6 or 7**), ensuring to use the compression sleeve and anti-rotation washer as directed above and tighten to the recommended torque.
- Check bolt tightness regularly.

R&G

Unit 1, Shelley's Lane, East Worldham, Alton, Hampshire, GU34 3AQ

Tel: +44 (0)1420 89007 Fax: +44 (0)1420 87301 www.rg-racing.com Email: info@rg-racing.com



If mounting directly to the swingarm (Drilled fitment)

To fit the chain & sprocket guard to the swingarm, the swingarm will need to be drilled and tapped with 2 x M6 holes. Do not proceed if you are not comfortable completing this step: have fitted by a qualified technician.

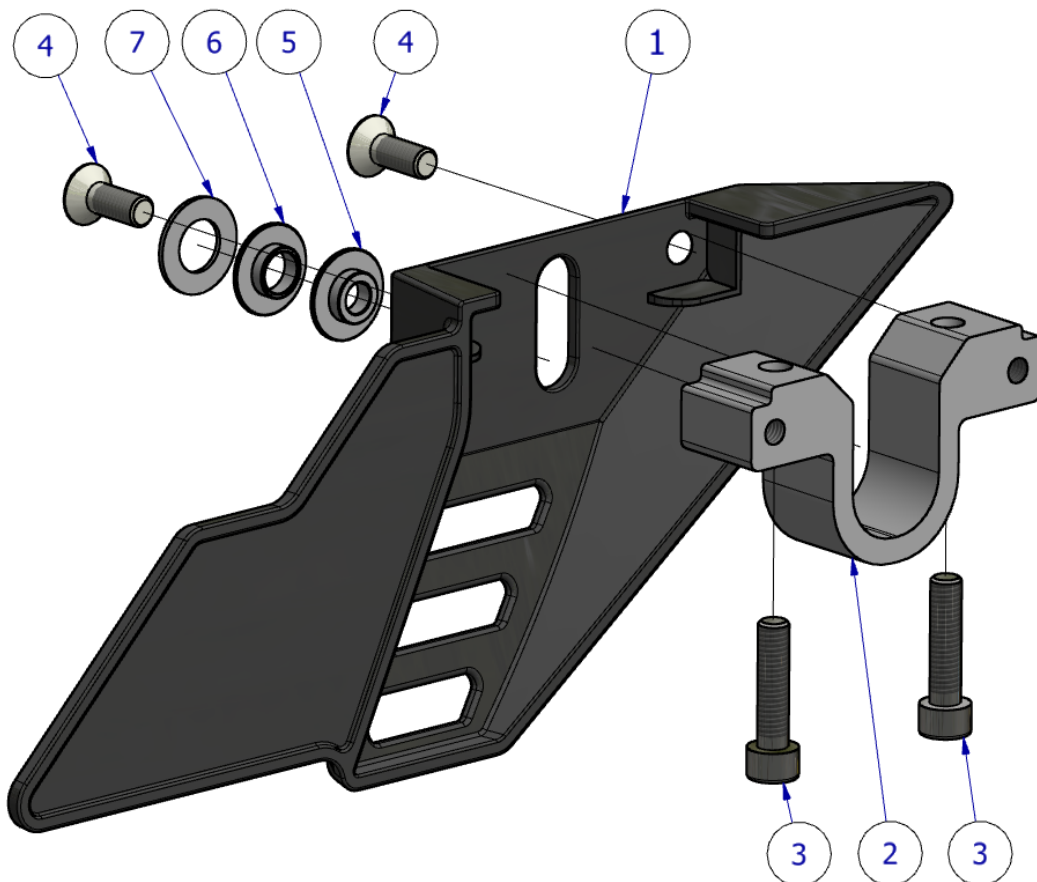

ASSEMBLY DIAGRAM 3

- Loosely assemble the Chain & Sprocket guard as shown in **Assembly Diagram 1** on page 3 and offer into position on the nearside of the swingarm. See fitting example on page 3 for intended coverage. **If intending to use in conjunction with a Cotton Reel, mount this as shown in the diagram on page 6 to help mark hole positions.**
- Disassemble the Chain and sprocket guard and mark the two hole positions with a pen or marking tool using the mounting block as a guide. *Ensure the holes are drilled away from the wall of the swingarm.*
- Use a punch or similar to ensure holes are drilled in the correct position.
- Once drilled, carefully tap the holes using an M6x1.00 Tap, using the mounting block (**item 2**) as a guide if necessary.
- Referring to **Assembly Diagram 3**, fit the Mounting Block (**M0614 - item 2**) onto the swingarm and fix in place using the two M6 cap head bolts (**item 3**), ensuring the cap heads fit into the recessed bore of the block. **Do not overtighten.** *Note: a small amount of thread locking compound on the bolts is recommended to keep the mounting block secure.*

R&G

Unit 1, Shelley's Lane, East Worldham, Alton, Hampshire, GU34 3AQ

Tel: +44 (0)1420 89007 Fax: +44 (0)1420 87301 www.rg-racing.com Email: info@rg-racing.com



- Slide the Chain & Sprocket guard (**item 1**) onto the outer slots of the mount block (**item 2**) and secure using the two countersunk M6 bolts (**item 4**) **Assembly diagram 3**, tightened to the correct torque.
- If fitting in conjunction with Cotton Reels, refer to the legend to select the correct size compression sleeve or washer and locate the small boss (if applicable) into the vertical Cotton Reel slot from the outside and fit Cotton Reel as shown in the example below (in this case, the anti-rotation washer is **not** required).

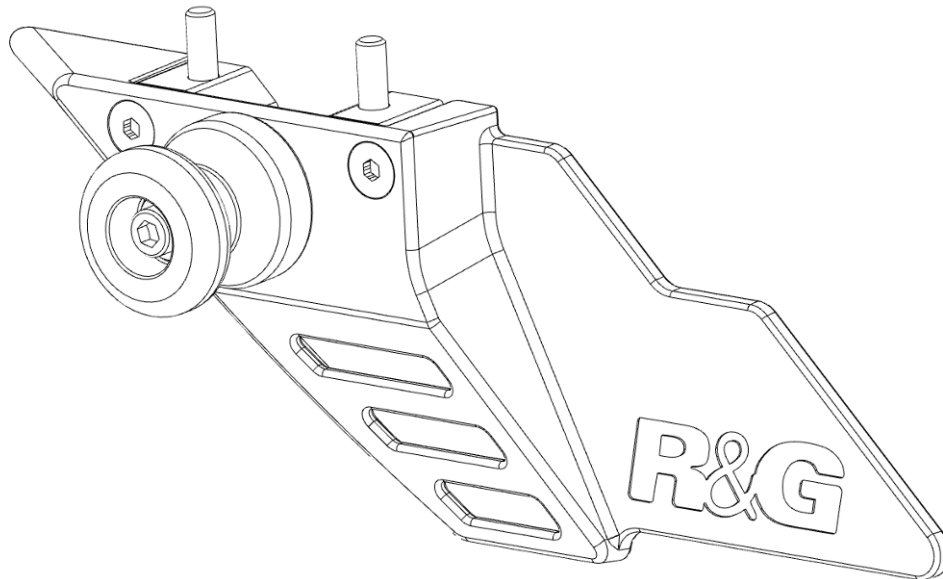

ISSUE 2 12/04/2021 (DM)

CONSUMER NOTICE

The catalogue description and any exhibition of samples are only broad indications of the Products and R&G may make design changes which do not diminish their performance or visual appeal and supplying them in such state shall conform to the order. The Buyer acknowledges no representation or warranty (other than as to title) has been given or will apply to the Products other than those in R&G's order or confirmation and the Buyer confirms it has chosen the Products as being of merchantable quality and suitable for its particular purposes. Where R&G fits the Products or undertakes other services it shall exercise reasonable skill and care and rectify any fault free of charge unless the workmanship has been disturbed. The Buyer is responsible for ensuring that the warranty on the motorcycle is not affected by the fitting of the Products. On return of any defective Products R&G shall at its option either supply a replacement or refund the purchase money but shall not be liable if the Products have been modified or used or maintained otherwise than in accordance with R&G's or manufacturer's instructions and good engineering practice or if the defect arises from accident or neglect. Other than identified above and subject to R&G not limiting its liability for causing death and personal injury, it shall not be liable for indirect or consequential loss and otherwise its liability shall be limited to the amounts paid by the Buyer for the Products or the fitting or service concerned. These terms do not affect the Buyer's statutory rights.

R&G RACING RETURNS POLICY (NON-FAULTY GOODS)

Returns must be pre-authorized (if not pre-authorized the return will be rejected). Goods may only be returned direct to us if they were purchased direct from us (customer must prove if necessary). Otherwise to be returned to original vendor. Goods must be in re-sellable condition, in the opinion of R&G Racing. All returns are subject to a 25% restocking and handling fee (25% of the gross value exc. P&P - at the prevailing price at time of purchase). The customer must pay any and all carriage charges. No returns of discontinued products, unless within 14 days of purchase. This policy does not affect your statutory rights and does not refer to faulty goods.

R&G

Unit 1, Shelley's Lane, East Worldham, Alton, Hampshire, GU34 3AQ

Tel: +44 (0)1420 89007 Fax: +44 (0)1420 87301 www.rg-racing.com Email: info@rg-racing.com



NOTICE DE MONTAGE TG0019 PROTECTION CHAINE
INSTALLATION UNIVERSELLE



CE KIT CONTIENT LES ARTICLES ILLUSTRÉS ET ÉTIQUETES SUR LA PAGE.

CERTAINES PARTIES PEUVENT ÊTRE PRÉSENTES UNIQUEMENT POUR LA CLARTÉ DES INSTRUCTIONS.

NE PAS PROCÉDER AU MONTAGE TANT QUE VOUS N'ÊTES PAS SÛR QUE TOUTES LES PIÈCES SOIENT PRÉSENTES.

VEUILLEZ LIRE TOUTES LES INSTRUCTIONS AVANT DE CONTINUER.

EN CAS DE DOUTE LORS DU MONTAGE DE NOS PRODUITS, CONSULTEZ UN DE NOS REVENDEURS OU FAITES APPEL À UN TECHNICIEN QUALIFIÉ.

VEUILLEZ NOTER QUE LA FAÇON DONT LE KIT EST EMBALLÉ NE REPRÉSENTE PAS NECESSAIREMENT LA MANIÈRE DE LE MONTER SUR LA MOTO.

SI DES RONDELLES EN CAOUTCHOUC SONT UTILISÉES POUR MAINTENIR LES COMPOSANTS SUR LES BOULONS, ELLES PEUVENT ÊTRE JETÉES.

NOTICE DISPONIBLE AU TÉLÉCHARGEMENT SUR : WWW.RG-RACING.COM

R&G

Unit 1, Shelley's Lane, East Worldham, Alton, Hampshire, GU34 3AQ
Tel: +44 (0)1420 89007 Fax: +44 (0)1420 87301 www.rg-racing.com Email: info@rg-racing.com



<u>OUTILS REQUIS</u>	<u>VALEURS DE SERRAGE</u>
<ul style="list-style-type: none"> • PERCEUSE + FORET 5MM • M6 x 1.00 CLÉ À TARAUD <ul style="list-style-type: none"> • MARQUEUR • POINÇON • CLÉS HEXAGONALES 4mm & 5mm 	M4 BOULON = 8Nm M5 BOULON = 12Nm M6 BOULON = 15Nm M8 BOULON = 20Nm M10 BOULON = 40Nm M12 BOULON = 40Nm

LÉGENDE

ARTICLE No.	DESCRIPTION	QTÉ
ARTICLE 1	MTG0019 PROTECTION DE CHAÎNE & PIGNON	1
ARTICLE 2	M0614 BLOC DE MONTAGE	1
ARTICLE 3	M6x25MM BOULON	2
ARTICLE 4	M6x15MM BOULONS	2
ARTICLE 5	S1283 M6 MANCHON DE COMPRESSION	1
ARTICLE 6	S1284 M8 MANCHON DE COMPRESSION	1
ARTICLE 7	M10x19MM O/D RONDELLE	1
ARTICLE 8	M10 RONDELLE ANTI ROTATION	1
ARTICLE 9	M6x25mm BOULON	1
ARTICLE 10	M8x25mm BOULON	1
ARTICLE 11	M10x25mm BOULON	1

NOTICE DE MONTAGE

LES INSTRUCTIONS CI-DESSOUS DÉTAILLENT DEUX OPTIONS DE MONTAGE SÉPARÉES. CHOISISSEZ CE QUI EST LE PLUS ADAPTÉ À VOTRE MOTO.

- Pour toutes les options de montage, lors du positionnement de la protection de chaîne et de pignon, assurez-vous que:
 - La chaîne inférieure et la zone du pignon soient couvertes.
 - La section arrière plate de la protection de la chaîne et du pignon doit couvrir la section inférieure du pignon.
 - La chaîne et la protection de pignon doivent être placées parallèlement à la chaîne à un endroit où elles ne peuvent entrer en contact avec les composants mobiles de la moto. Tenez compte de tout mouvement vertical ou latéral de la chaîne et de la roue lors de la mise en place de la protection de chaîne et de pignon.
 - Soit les motos sont équipés d'un bossage inférieur pour les bobines de protection de rechange à utiliser avec une béquille de stand. Le cas échéant, le bloc de montage (article 2) peut être placé sur celui-ci pour une plus grande flexibilité lors du montage,

R&G

Unit 1, Shelley's Lane, East Worldham, Alton, Hampshire, GU34 3AQ

Tel: +44 (0)1420 89007 Fax: +44 (0)1420 87301 www.rg-racing.com Email: info@rg-racing.com



dans ce cas, installez la bobine pour aider à positionner le bloc comme indiqué dans l'exemple de la page 3.

- Voir l'exemple du cache prévu ci-dessous:

CACHE PRÉVU



SCHÉMA D'ENSEMBLE



R&G

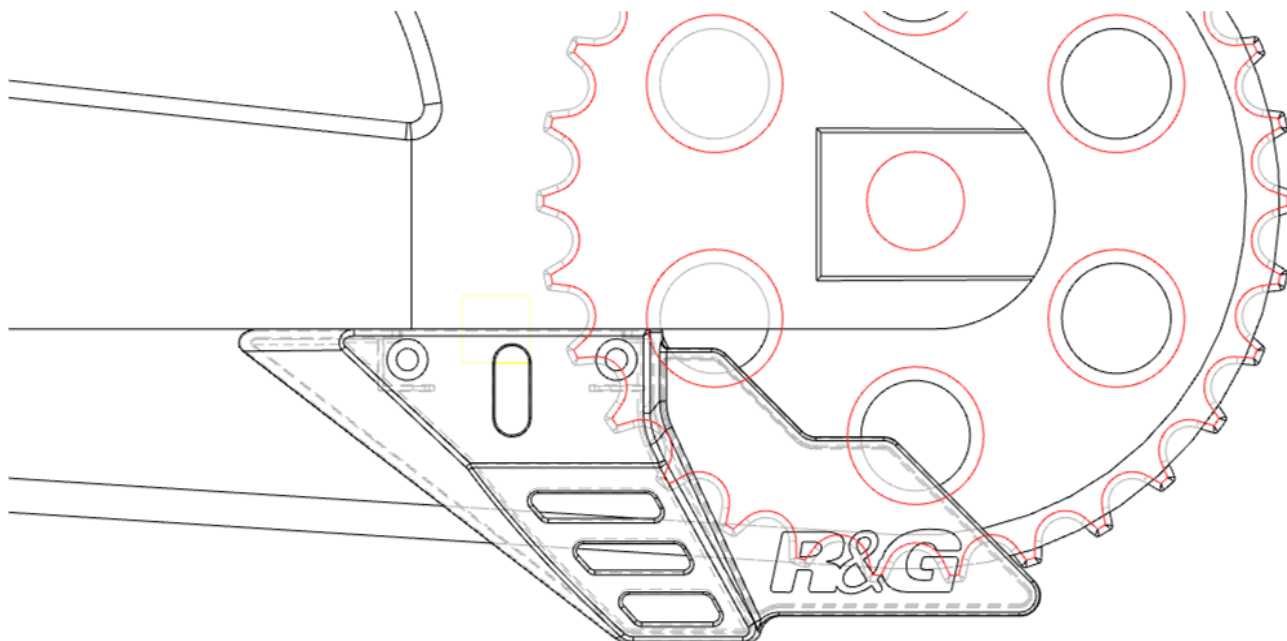
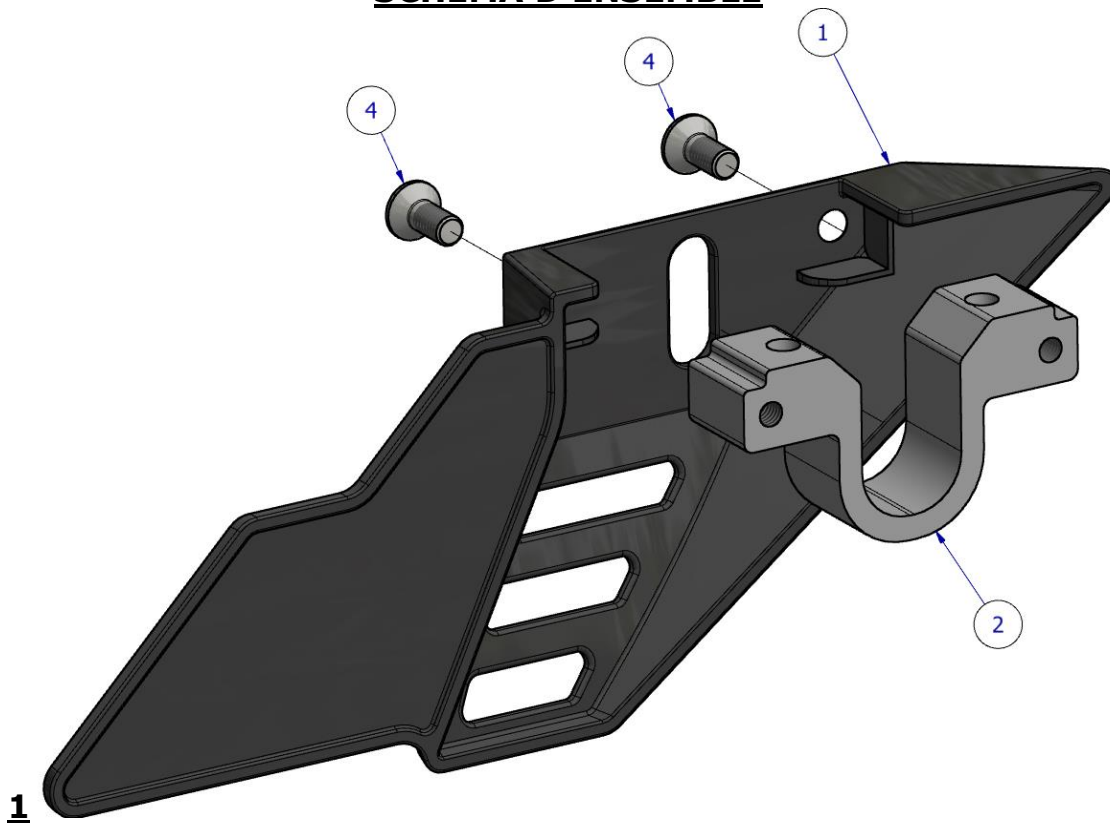

SCHÉMA D'ENSEMBLE 2

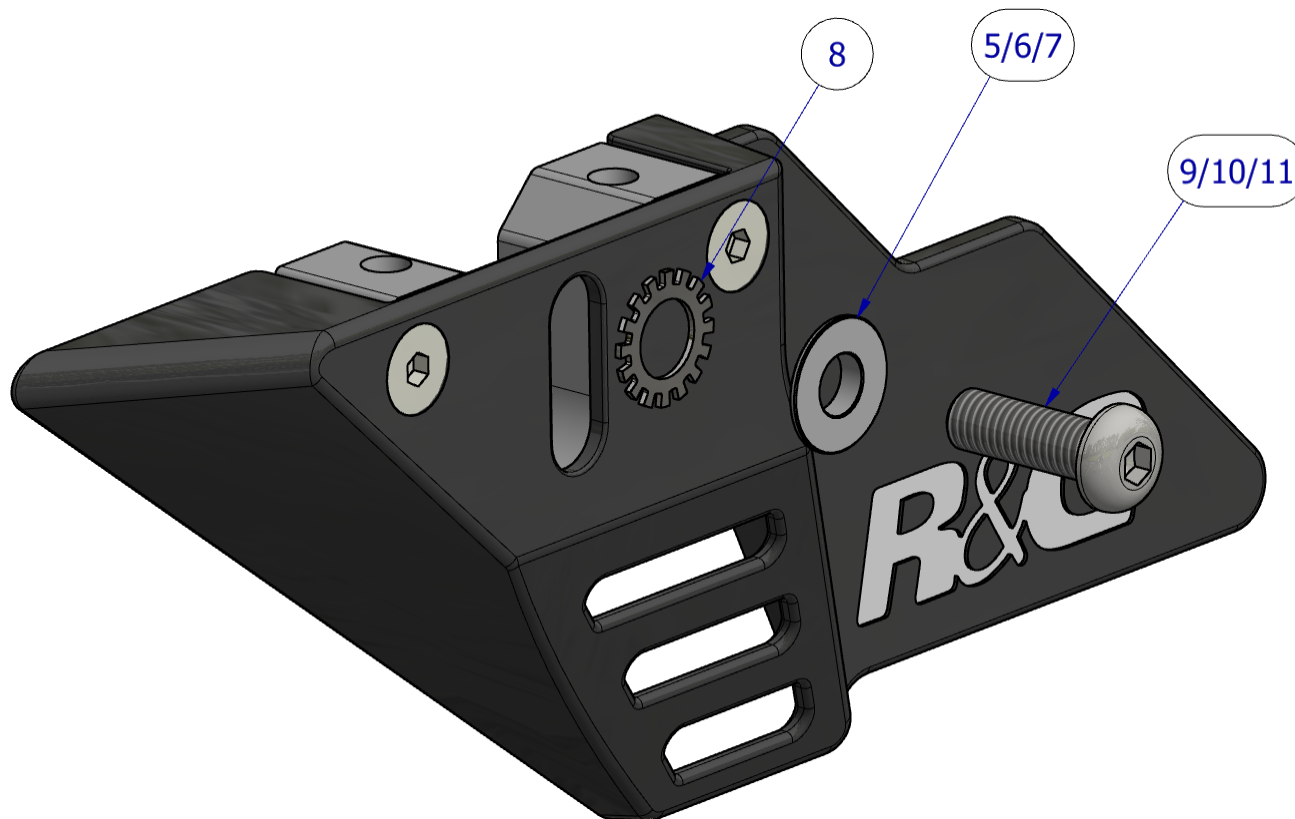

Si le montage utilise le support de bobine de protection d'origine (montage non percé)

- Sur certaines motos, il est possible de monter la chaîne et le carter de pignon à l'aide du bossage inférieur du bras oscillant pour le montage de la bobine de coton sans modification du bras oscillant.
- Assemblez la protection de chaîne et de pignon selon le schéma d'assemblage 1 ci-dessus en fixant le bloc de montage en aluminium (M0614 - article 2) à la protection de chaîne et de pignon (article 1) à l'aide des boulons à tête fraisée (article 4) serrés au couple recommandé.
- Ensuite, en vous référant à la légende, utilisez la taille de boulon et de manchon de compression correspondant à votre moto en conjonction avec la rondelle anti-rotation M10 (article 8) pour fixer l'ensemble en place comme indiqué sur le schéma d'assemblage 2, en vous assurant que la rondelle anti-rotation M10 (article 8) repose contre la chaîne en plastique et la protection du pignon (cette rondelle «s'emboîte» dans la protection pour empêcher tout mouvement lors de la conduite).
- Serrez le boulon au couple recommandé et vérifiez que la protection soit bien fixée.
- En cas de montage avec des bobines de protection, procéder de la même manière en utilisant le boulon de bobine de protection à la place du boulon inclus avec ce kit, avec la bobine à l'extérieur du manchon de compression (article 5, 6 ou 7) , en veillant à utiliser le manchon de compression et la rondelle anti-rotation comme indiqué ci-dessus et à serrer au couple recommandé.

Vérifiez régulièrement le serrage des boulons.

R&G

Unit 1, Shelley's Lane, East Worldham, Alton, Hampshire, GU34 3AQ

Tel: +44 (0)1420 89007 Fax: +44 (0)1420 87301 www.rg-racing.com Email: info@rg-racing.com

En cas de montage directement sur le bras oscillant (montage percé)

Pour monter la chaîne et la protection de pignon sur le bras oscillant, le bras oscillant devra être percé et taraudé avec 2 trous M6. Ne continuez pas si vous n'êtes pas à l'aise pour effectuer cette étape: faites-le monter par un technicien qualifié.



SCHÉMA D'ENSEMBLE 3

- Assemblez sans serrer la protection de la chaîne et du pignon comme indiqué sur le schéma d'assemblage 1 à la page 3 et mettez-la en place sur le côté proche du bras oscillant. Voir l'exemple de montage à la page 3 pour la couverture prévue. Si vous prévoyez de l'utiliser avec une bobine, montez-la comme indiqué sur le schéma de la page 6 pour vous aider à marquer les positions des trous.
- Démontez la chaîne et la protection de pignon et marquez les deux positions des trous avec un stylo ou un outil de marquage en utilisant le bloc de montage comme guide. Assurez-vous que les trous soient percés loin de la paroi du bras oscillant.
- Utilisez un poinçon ou similaire pour vous assurer que les trous soient percés dans la bonne position.
- Une fois percés, tarauder soigneusement les trous à l'aide d'un taraud M6x1.00, en utilisant le bloc de montage (article 2) comme guide si nécessaire.
- En vous référant au schéma d'assemblage 3, montez le bloc de montage (M0614 - article 2) sur le bras oscillant et fixez-le en place à l'aide des deux boulons à tête cylindrique M6 (article 3), en veillant à ce que les têtes à chapeau s'insèrent dans l'alésage encastré du bloc. Ne pas trop

R&G

Unit 1, Shelley's Lane, East Worldham, Alton, Hampshire, GU34 3AQ

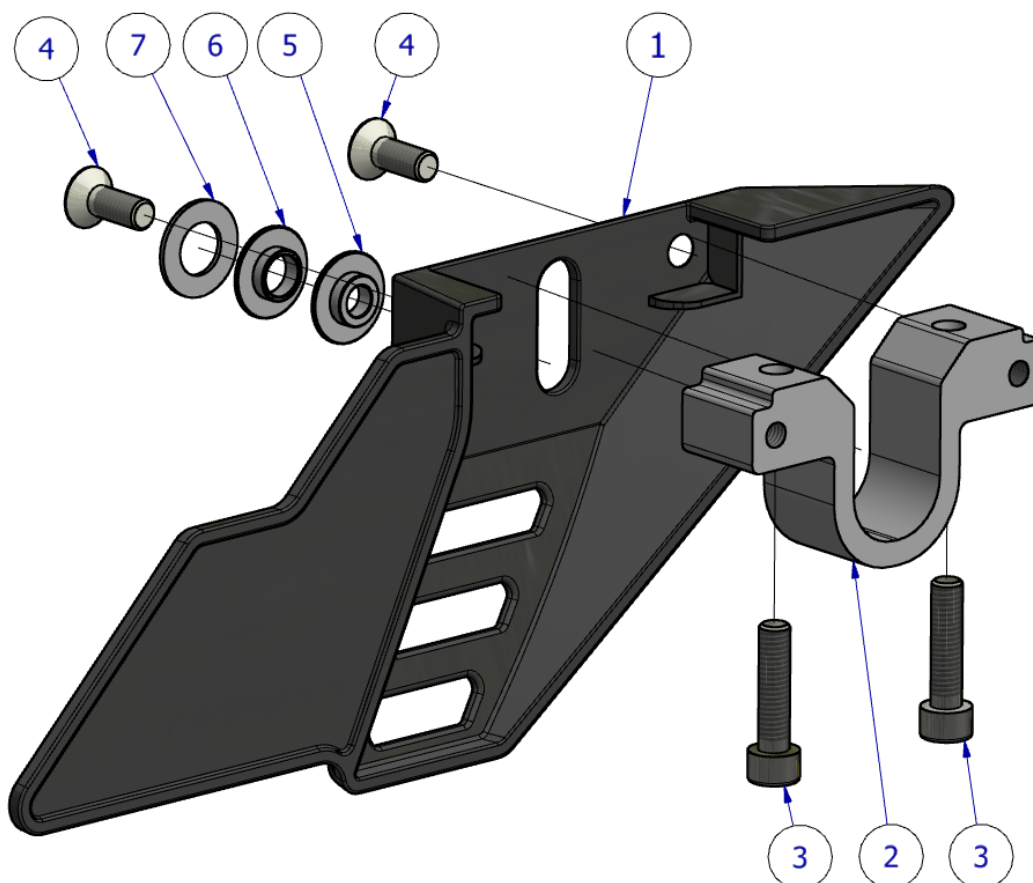
Tel: +44 (0)1420 89007 Fax: +44 (0)1420 87301 www.rg-racing.com Email: info@rg-racing.com



serrer. Remarque: une petite quantité de composé de blocage de filetage sur les boulons est recommandée pour maintenir le bloc de montage sécurisé.

- Faites glisser la protection de chaîne et de pignon (article 1) sur les fentes extérieures du bloc de montage (article 2) et fixez-la à l'aide des deux boulons fraisés M6 (article 4) comme indiqué sur le schéma d'assemblage 3, serrés au couple correct.
- En cas de montage avec des bobines de protection, reportez-vous à la légende pour sélectionner le manchon de compression ou la rondelle de taille correcte et localisez le petit bossage (le cas échéant) dans la fente verticale de la bobine de protection de l'extérieur et installez la bobine comme indiqué dans l'exemple ci-dessous (dans ce cas, la rondelle anti-rotation n'est pas nécessaire).

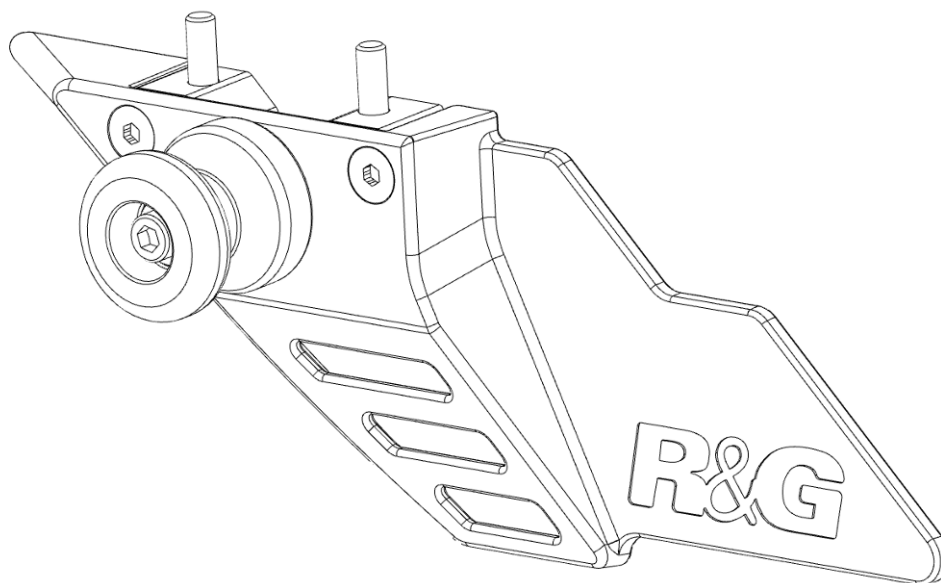

ISSUE 2 12/04/2021 (DM)

CONSUMER NOTICE

The catalogue description and any exhibition of samples are only broad indications of the Products and R&G may make design changes which do not diminish their performance or visual appeal and supplying them in such state shall conform to the order. The Buyer acknowledges no representation or warranty (other than as to title) has been given or will apply to the Products other than those in R&G's order or confirmation and the Buyer confirms it has chosen the Products as being of merchantable quality and suitable for its particular purposes. Where R&G fits the Products or undertakes other services it shall exercise reasonable skill and care and rectify any fault free of charge unless the workmanship has been disturbed. The Buyer is responsible for ensuring that the warranty on the motorcycle is not affected by the fitting of the Products. On return of any defective Products R&G shall at its option either supply a replacement or refund the purchase money but shall not be liable if the Products have been modified or used or maintained otherwise than in accordance with R&G's or manufacturer's instructions and good engineering practice or if the defect arises from accident or neglect. Other than identified above and subject to R&G not limiting its liability for causing death and personal injury, it shall not be liable for indirect or consequential loss and otherwise its liability shall be limited to the amounts paid by the Buyer for the Products or the fitting or service concerned. These terms do not affect the Buyer's statutory rights.

R&G RACING RETURNS POLICY (NON-FAULTY GOODS)

Returns must be pre-authorized (if not pre-authorized the return will be rejected). Goods may only be returned direct to us if they were purchased direct from us (customer must prove if necessary). Otherwise to be returned to original vendor. Goods must be in re-sellable condition, in the opinion of R&G Racing. All returns are subject to a 25% restocking and handling fee (25% of the gross value exc. P&P - at the prevailing price at time of purchase). The customer must pay any and all carriage charges. No returns of discontinued products, unless within 14 days of purchase. This policy does not affect your statutory rights and does not refer to faulty goods.

R&G

Unit 1, Shelley's Lane, East Worldham, Alton, Hampshire, GU34 3AQ

Tel: +44 (0)1420 89007 Fax: +44 (0)1420 87301 www.rg-racing.com Email: info@rg-racing.com