

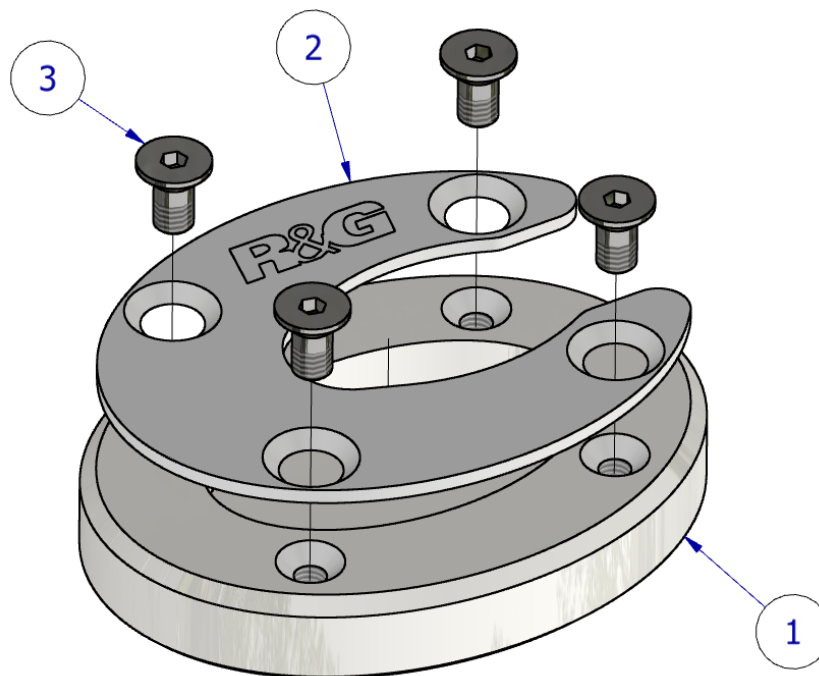

FITTING INSTRUCTIONS FOR PKS0177SI KICKSTAND SHOE



THIS KIT CONTAINS THE ITEMS PICTURED AND LABELLED OVER PAGE.

SOME PARTS MAY BE SHOWN FOR CLARITY OF INSTRUCTIONS ONLY.

DO NOT PROCEED UNTIL YOU ARE SURE ALL PARTS ARE PRESENT.

PLEASE READ ALL INSTRUCTIONS BEFORE PROCEEDING.

IF IN ANY DOUBT WHEN FITTING OUR PRODUCTS, CONSULT ONE OF OUR DEALERS OR HAVE FITTED BY A QUALIFIED TECHNICIAN.

Please note that the way the kit is packed does not necessarily represent the way of mounting to the bike.

In the event of rubber washers being used to hold components onto bolts, these rubber washers can be thrown away.

DIGITAL COPIES OF THESE INSTRUCTIONS ARE AVAILABLE FROM

WWW.RG-RACING.COM

R&G

Unit 1, Shelley's Lane, East Worldham, Alton, Hampshire, GU34 3AQ

Tel: +44 (0)1420 89007 Fax: +44 (0)1420 87301 www.rg-racing.com Email: info@rg-racing.com



<p><u>TOOLS REQUIRED</u></p> <ul style="list-style-type: none"> • 3mm A/F Allen key or bit. • Thread locking compound. 	<p>• <u>GENERAL TORQUE SETTINGS</u></p> <ul style="list-style-type: none"> • M4 BOLT = 8Nm • M5 BOLT = 12Nm • M6 BOLT = 15Nm • M8 BOLT = 20Nm • M10 BOLT = 40Nm • M12 BOLT = 40Nm
---	--

LEGEND

ITEM No.	DESCRIPTION	QTY
ITEM 1	MOUNTING PLATE (MP0283)	1
ITEM 2	CLAMP PLATE (PLATE 0312)	1
ITEM 3	M5 x 10mm LONG STAINLESS-STEEL COUNTERSUNK BOLTS	4
ITEM 4	50mm STRIP OF SELF-ADHESIVE FOAM	1

FITTING INSTRUCTIONS

- Take the machined aluminium mounting plate (**item 1**) and fit to the base of the side stand from underneath.
- Pass the clamping plate (**item 2**) around the side stand leg with the countersinks facing upwards.
- Sandwich the two plates together around the side stand pad.
- Apply a small amount of (one drop) of thread locking compound to the threaded end of each countersunk bolts (**item 3**).
- Fit the four bolts (**item 3**) through the clamp plate and into the mounting plate, clamping the two plates securely together to the side stand pad as shown in the assembly diagram on page 1.
- Tighten all the bolts evenly and ensure the stand is clear of the swingarm and chain when in the raised position.
- If fitting to older used stands that have wear, the self-adhesive foam strip (**item 4**) should be cut and placed into the base plate to ensure a tight fit.

ISSUE 1 - 24/07/2023 (DM)

R&G

Unit 1, Shelley's Lane, East Worldham, Alton, Hampshire, GU34 3AQ
 Tel: +44 (0)1420 89007 Fax: +44 (0)1420 87301 www.rg-racing.com Email: info@rg-racing.com

**CONSUMER NOTICE**

The catalogue description and any exhibition of samples are only broad indications of the Products and R&G may make design changes which do not diminish their performance or visual appeal and supplying them in such state shall conform to the order. The Buyer acknowledges no representation or warranty (other than as to title) has been given or will apply to the Products other than those in R&G's order or confirmation and the Buyer confirms it has chosen the Products as being of merchantable quality and suitable for its particular purposes. Where R&G fits the Products or undertakes other services it shall exercise reasonable skill and care and rectify any fault free of charge unless the workmanship has been disturbed. The Buyer is responsible for ensuring that the warranty on the motorcycle is not affected by the fitting of the Products. On return of any defective Products R&G shall at its option either supply a replacement or refund the purchase money but shall not be liable if the Products have been modified or used or maintained otherwise than in accordance with R&G's or manufacturer's instructions and good engineering practice or if the defect arises from accident or neglect. Other than identified above and subject to R&G not limiting its liability for causing death and personal injury, it shall not be liable for indirect or consequential loss and otherwise its liability shall be limited to the amounts paid by the Buyer for the Products or the fitting or service concerned. These terms do not affect the Buyer's statutory rights.

R&G RACING RETURNS POLICY (NON-FAULTY GOODS)

Returns must be pre-authorized (if not pre-authorized the return will be rejected). Goods may only be returned direct to us if they were purchased direct from us (customer must prove if necessary). Otherwise to be returned to original vendor. Goods must be in re-sellable condition, in the opinion of R&G Racing. All returns are subject to a 25% restocking and handling fee (25% of the gross value exc. P&P – at the prevailing price at time of purchase). The customer must pay any and all carriage charges. No returns of discontinued products, unless within 14 days of purchase. This policy does not affect your statutory rights and does not refer to faulty goods.

R&G

Unit 1, Shelley's Lane, East Worldham, Alton, Hampshire, GU34 3AQ

Tel: +44 (0)1420 89007 Fax: +44 (0)1420 87301 www.rg-racing.com Email: info@rg-racing.com



NOTICE DE MONTAGE POUR PKS0177SI PIED DE BÉQUILLE

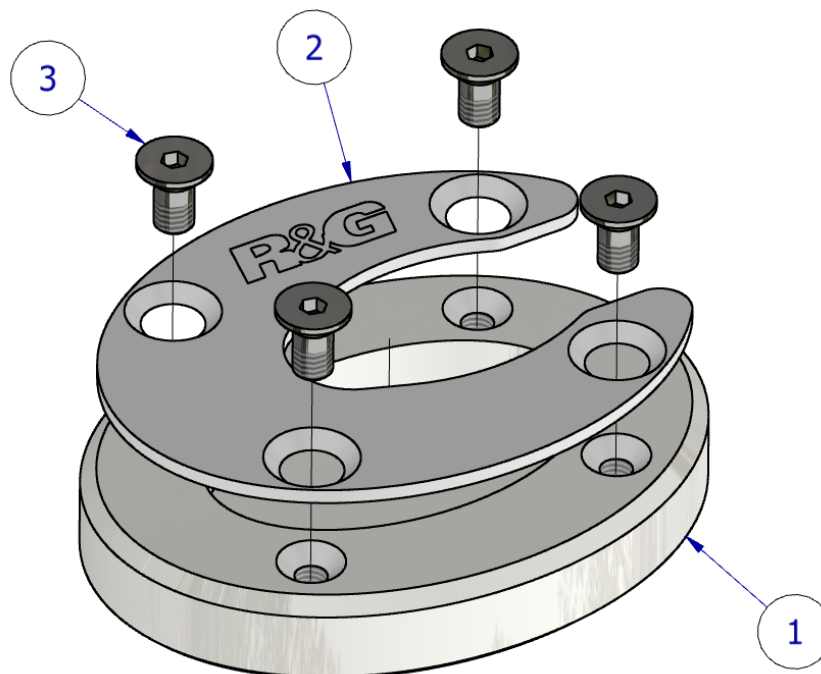

CE KIT CONTIENT LES ARTICLES ILLUSTRÉS ET ÉTIQUETÉS SUR LA PAGE.

CERTAINES PIÈCES PEUVENT ÊTRE INDIQUÉES UNIQUEMENT POUR LA CLARTÉ DES INSTRUCTIONS.

NE PAS CONTINUER AVANT D'ÊTRE SÛR DE LA PRÉSENCE DE TOUTES LES PIÈCES.

VEUILLEZ LIRE TOUTES LES INSTRUCTIONS AVANT DE CONTINUER.

**EN CAS DE DOUTE LORS DE L'INSTALLATION DE NOS PRODUITS, CONSULTEZ UN DE NOS
REVENDEURS OU FAITES INSTALLER PAR UN TECHNICIEN QUALIFIÉ**

VEUILLEZ NOTER QUE LA FAÇON DONT LE KIT EST EMBALLÉ NE REPRÉSENTE PAS NÉCESSAIREMENT
LE MODE DE MONTAGE SUR LA MOTO.

EN CAS D'UTILISATION DE RONDELLES EN CAOUTCHOUC POUR MAINTENIR LES COMPOSANTS SUR
LES BOULONS, CES RONDELLES EN CAOUTCHOUC PEUVENT ÊTRE JETÉES.

NOTICE DE MONTAGE DISPONIBLE AU TÉLÉCHARGEMENT SUR :

WWW.RG-RACING.COM

R&G

Unit 1, Shelley's Lane, East Worldham, Alton, Hampshire, GU34 3AQ

Tel: +44 (0)1420 89007 Fax: +44 (0)1420 87301 www.rg-racing.com Email: info@rg-racing.com



<u>OUTILS REQUIS</u>	<u>VALEURS DE SERRAGE</u>
<ul style="list-style-type: none"> • Clé Allen 3mm • Frein filet 	BOULON M4 = 8Nm BOULON M5 = 12Nm BOULON M6 = 15Nm BOULON M8 = 20Nm BOULON M10 = 40Nm BOULON M12 = 40Nm

LÉGENDE

ARTICLE No.	DESCRIPTION	QTÉ
ARTICLE 1	PLAQUE DE MONTAGE (MP0283)	1
ARTICLE 2	PLAQUE DE SERRAGE (PLATE 0312)	1
ARTICLE 3	M5 x 10mm BOULONS	4
ARTICLE 4	50mm BANDE DE MOUSSE AUTO-ADHÉSIVE	1

NOTICE DE MONTAGE

- Prenez la plaque de montage en aluminium usinée (article 1) et fixez-la à la base de la béquille latérale par le dessous.
- Enserrez les deux plaques ensemble autour du rembourrage de la béquille latérale.
- Appliquez une petite quantité (une goutte) de bleu Loctite 242 sur l'extrémité filetée de chaque boulon à tête fraisée (article 3).
- Montez les quatre boulons (Article 3) à travers la plaque de serrage et dans la plaque de montage en serrant solidement les deux plaques ensemble sur le rembourrage de la béquille latérale comme sur le schéma en page 1.
- Serrez tous les boulons uniformément et assurez-vous que la béquille soit dégagée du bras oscillant et de la chaîne lorsqu'elle est en position relevée.
- En cas d'installation sur des supports usagés plus anciens, la bande de mousse adhésive (article 4) doit être coupée et placée sur la plaque de base pour assurer un ajustement serré.

ISSUE 1 - 24/07/2023 (DM)

R&G

Unit 1, Shelley's Lane, East Worldham, Alton, Hampshire, GU34 3AQ
 Tel: +44 (0)1420 89007 Fax: +44 (0)1420 87301 www.rg-racing.com Email: info@rg-racing.com