



FITTING INSTRUCTIONS FOR PKS0161SI KICKSTAND SHOE TO FIT HARLEY DAVIDSON PAN AMERICA 1250 2022-



THIS KIT CONTAINS THE ITEMS PICTURED AND LABELLED OVER PAGE.

SOME PARTS MAY BE SHOWN FOR CLARITY OF INSTRUCTIONS ONLY.

DO NOT PROCEED UNTIL YOU ARE SURE ALL PARTS ARE PRESENT.

PLEASE READ ALL INSTRUCTIONS BEFORE PROCEEDING.

IF IN ANY DOUBT WHEN FITTING OUR PRODUCTS, CONSULT ONE OF OUR DEALERS OR HAVE FITTED BY A QUALIFIED TECHNICIAN.

Please note that the way the kit is packed does not necessarily represent the way of mounting to the bike.

In the event of rubber washers being used to hold components onto bolts, these rubber washers can be thrown away.

DIGITAL COPIES OF THESE INSTRUCTIONS ARE AVAILABLE FROM

WWW.RG-RACING.COM

R&G

Unit 1, Shelley's Lane, East Worldham, Alton, Hampshire, GU34 3AQ

Tel: +44 (0)1420 89007 Fax: +44 (0)1420 87301 www.rg-racing.com Email: info@rg-racing.com

**TOOLS REQUIRED**

- 3mm A/F Allen key or bit.
- Thread locking compound.

- **GENERAL TORQUE SETTINGS**

- M4 BOLT = 8Nm
- M5 BOLT = 12Nm
- M6 BOLT = 15Nm
- M8 BOLT = 20Nm
- M10 BOLT = 40Nm
- M12 BOLT = 40Nm

LEGEND

ITEM No.	DESCRIPTION	QTY
ITEM 1	MOUNTING PLATE (MP0268)	1
ITEM 2	CLAMP PLATE (PLATE0291)	1
ITEM 3	BUMP STOP EXTENSION BRACKET (SMW0219)	1
ITEM 4	M5x8mm LONG STAINLESS-STEEL COUNTERSUNK BOLTS	4
ITEM 5	M6x20mm COUNTER SUNK BOLT	1
ITEM 6	50mm STRIP OF SELF-ADHESIVE FOAM	1

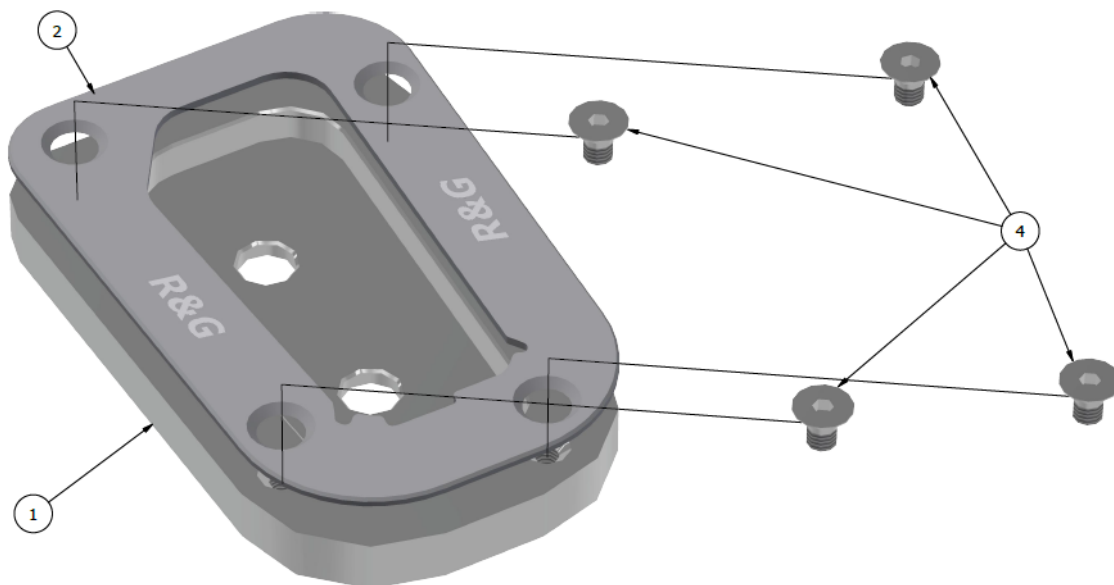
EXPLODED DIAGRAM

R&G

Unit 1, Shelley's Lane, East Worldham, Alton, Hampshire, GU34 3AQ

Tel: +44 (0)1420 89007 Fax: +44 (0)1420 87301 www.rg-racing.com Email: info@rg-racing.com



FITTING PICTURES

PICTURE 1

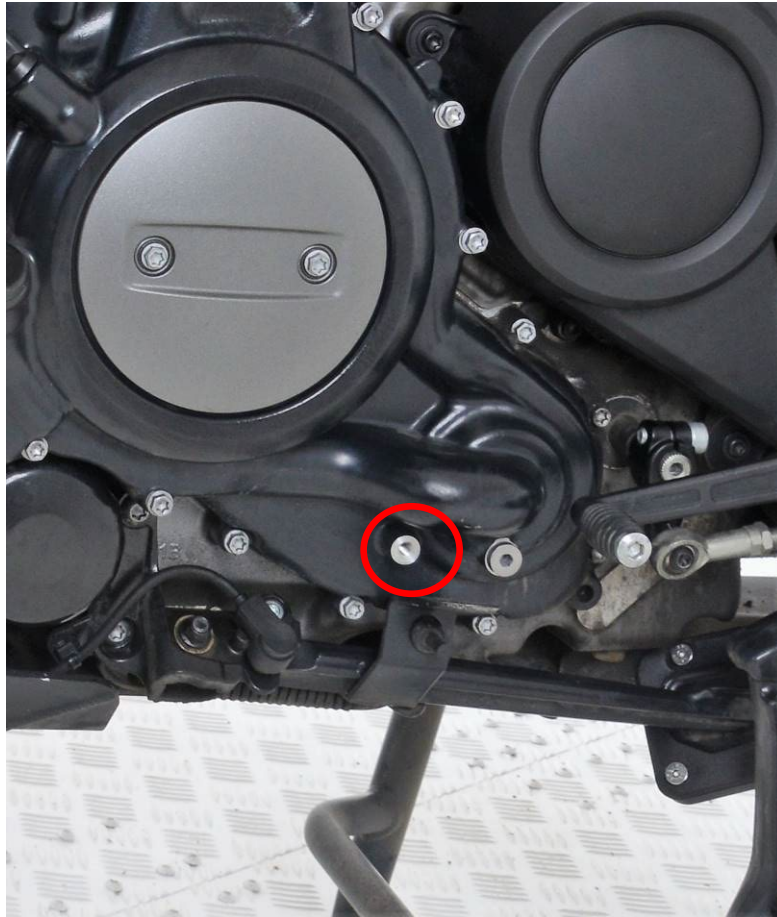

PICTURE 2





FITTING INSTRUCTIONS

- Carefully pass the clamping plate (**Item 2**) around the side stand leg with the countersinks facing upwards.
- Take the machined aluminium mounting plate (**Item 1**) and fit to the base of the side stand from underneath.
- Sandwich the two plates together around the side stand foot.
- Apply a small amount of (one drop) of thread locking compound to the threaded end of each countersunk bolt (**Item 4**).
- Fit the four bolts (**Item 4**) through the clamp plate and into the mounting plate, clamping the two plates securely together to the side stand foot as shown in the **Exploded Diagram**.
- Tighten all the bolts evenly and ensure the stand is clear of the swingarm and chain when in the raised position.
- If fitting to older used stands that have wear, the self-adhesive foam strip (**Item 4**) should be cut and placed into the base plate to ensure a tight fit.

FITTING BUMP STOP BRACKET

Due to side stand length changes on the Pan America, a side stand bump-stop extension bracket may be required for the kickstand shoe to clear the engine block.

- Offer the bump stop bracket up to the LHS engine case, where you will find an empty threaded hole. (**Picture 1**)
- Push the M6 counter sunk bolt (**Item 5**) through the bump stop bracket (**Item 3**) and tighten down, the assembly should look similar to **Picture 2**.

ISSUE 1 - 27/07/2022 (TB)

CONSUMER NOTICE

The catalogue description and any exhibition of samples are only broad indications of the Products and R&G may make design changes which do not diminish their performance or visual appeal and supplying them in such state shall conform to the order. The Buyer acknowledges no representation or warranty (other than as to title) has been given or will apply to the Products other than those in R&G's order or confirmation and the Buyer confirms it has chosen the Products as being of merchantable quality and suitable for its particular purposes. Where R&G fits the Products or undertakes other services it shall exercise reasonable skill and care and rectify any fault free of charge unless the workmanship has been disturbed. The Buyer is responsible for ensuring that the warranty on the motorcycle is not affected by the fitting of the Products. On return of any defective Products R&G shall at its option either supply a replacement or refund the purchase money but shall not be liable if the Products have been modified or used or maintained otherwise than in accordance with R&G's or manufacturer's instructions and good engineering practice or if the defect arises from accident or neglect. Other than identified above and subject to R&G not limiting its liability for causing death and personal injury, it shall not be liable for indirect or consequential loss and otherwise its liability shall be limited to the amounts paid by the Buyer for the Products or the fitting or service concerned. These terms do not affect the Buyer's statutory rights.

R&G RACING RETURNS POLICY (NON-FAULTY GOODS)

Returns must be pre-authorized (if not pre-authorized the return will be rejected). Goods may only be returned direct to us if they were purchased direct from us (customer must prove if necessary). Otherwise to be returned to original vendor. Goods must be in re-sellable condition, in the opinion of R&G Racing. All returns are subject to a 25% restocking and handling fee (25% of the gross value exc. P&P – at the prevailing price at time of purchase). The customer must pay any and all carriage charges. No returns of discontinued products, unless within 14 days of purchase. This policy does not affect your statutory rights and does not refer to faulty goods.

R&G

Unit 1, Shelley's Lane, East Worldham, Alton, Hampshire, GU34 3AQ

Tel: +44 (0)1420 89007 Fax: +44 (0)1420 87301 www.rg-racing.com Email: info@rg-racing.com



**NOTICE DE MONTAGE POUR PKS0161SI PIED DE BÉQUILLE
HARLEY DAVIDSON PAN AMERICA 1250 2022-**



CE KIT CONTIENT LES ARTICLES ILLUSTRÉS ET ÉTIQUETÉS SUR LA PAGE.

CERTAINES PIÈCES PEUVENT ÊTRE INDIQUÉES UNIQUEMENT POUR LA CLARTÉ DES INSTRUCTIONS.

NE PAS CONTINUER AVANT D'ÊTRE SÛR DE LA PRÉSENCE DE TOUTES LES PIÈCES.

VEUILLEZ LIRE TOUTES LES INSTRUCTIONS AVANT DE CONTINUER.

**EN CAS DE DOUTE LORS DE L'INSTALLATION DE NOS PRODUITS, CONSULTEZ UN DE NOS
REVENDEURS OU FAITES INSTALLER PAR UN TECHNICIEN QUALIFIÉ**

VEUILLEZ NOTER QUE LA FAÇON DONT LE KIT EST EMBALLÉ NE REPRÉSENTE PAS
NÉCESSAIREMENT LE MODE DE MONTAGE SUR LE VÉLO.

EN CAS D'UTILISATION DE RONDELLES EN CAOUTCHOUC POUR MAINTENIR LES COMPOSANTS
SUR LES BOULONS, CES RONDELLES EN CAOUTCHOUC PEUVENT ÊTRE JETÉES.

NOTICE DE MONTAGE DISPONIBLE AU TÉLÉCHARGEMENT SUR :

WWW.RG-RACING.COM

R&G

Unit 1, Shelley's Lane, East Worldham, Alton, Hampshire, GU34 3AQ

Tel: +44 (0)1420 89007 Fax: +44 (0)1420 87301 www.rg-racing.com Email: info@rg-racing.com

**OUTILS REQUIS**

- Clé Allen 3mm.
- Composé de blocage de filetage .

VALEURS DE SERRAGE

- BOULON M4 = 8Nm
- BOULON M5 = 12Nm
- BOULON M6 = 15Nm
- BOULON M8 = 20Nm
- BOULON M10 = 40Nm
- BOULON M12 = 40Nm

LÉGENDE

ARTICLE No.	DESCRIPTION	QTÉ
ARTICLE 1	PLAQUE DE MONTAGE (MP0268)	1
ARTICLE 2	PLAQUE DE SERRAGE (PLATE0291)	1
ARTICLE 3	SUPPORT D'EXTENSION (SMW0219)	1
ARTICLE 4	M5x8mm BOULONS	4
ARTICLE 5	M6x20mm BOULON	1
ARTICLE 6	50mm BANDEAUX DE MOUSSE AUTOCOLLANTS	1

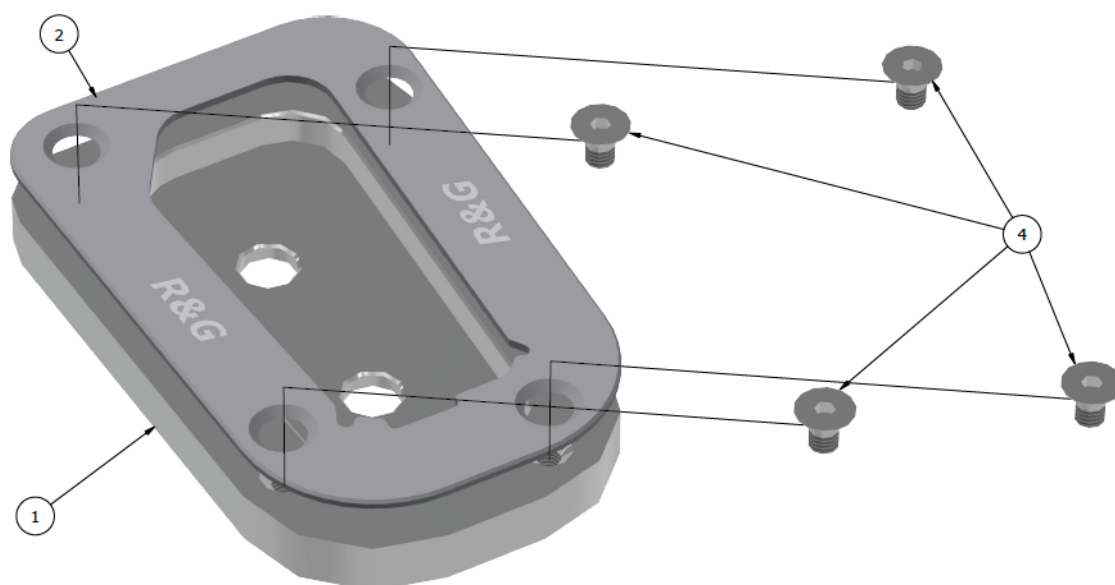
SCHÉMA D'ENSEMBLE

R&G

Unit 1, Shelley's Lane, East Worldham, Alton, Hampshire, GU34 3AQ

Tel: +44 (0)1420 89007 Fax: +44 (0)1420 87301 www.rg-racing.com Email: info@rg-racing.com



PHOTOS DE MONTAGE

PHOTO 1

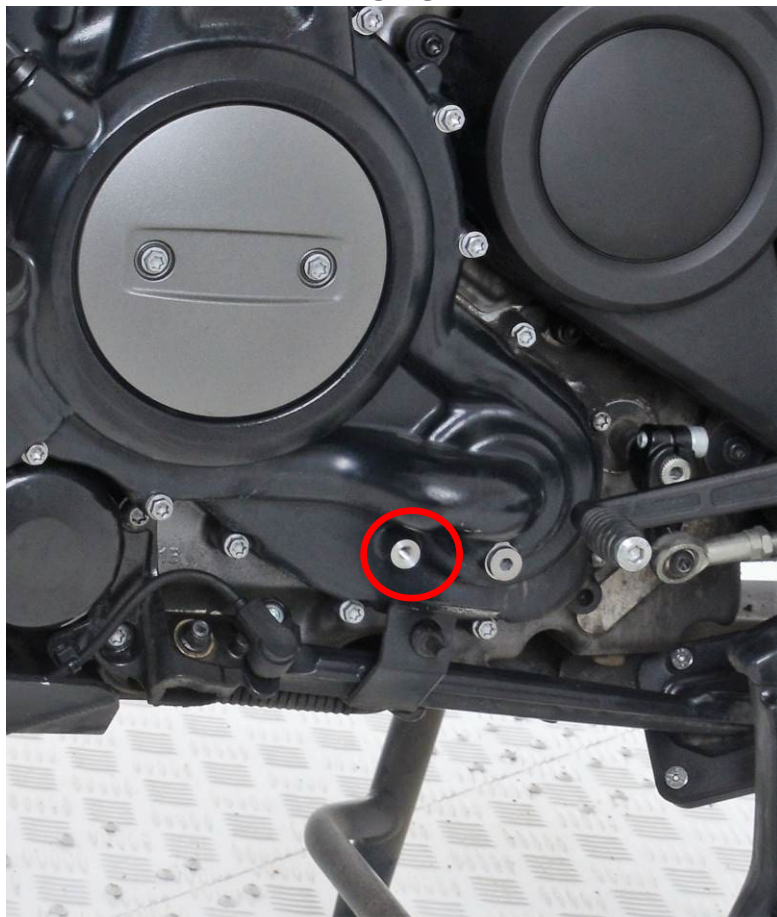
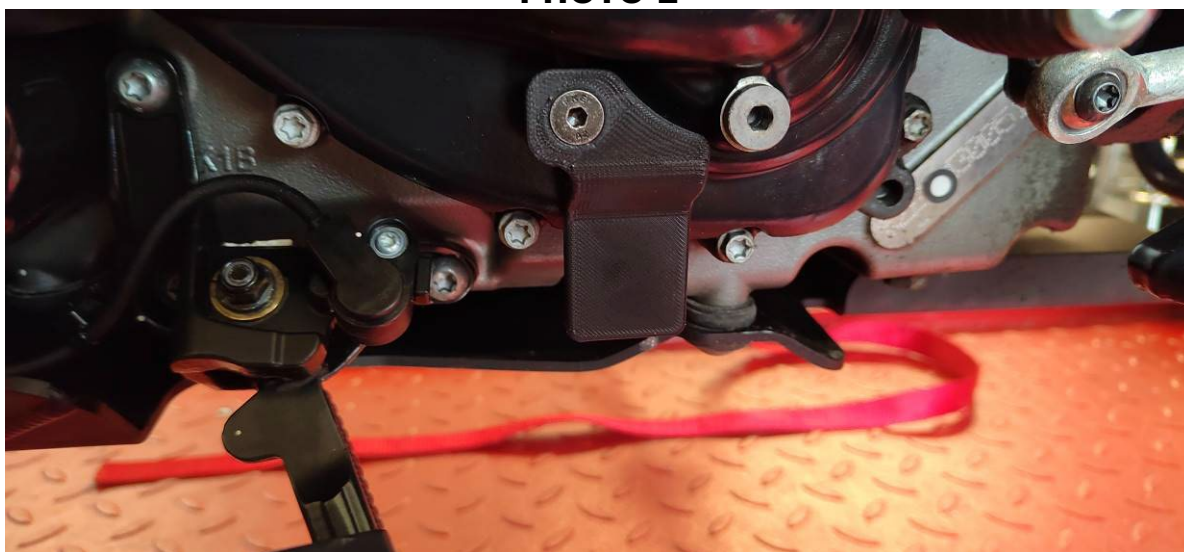

PHOTO 2





NOTICE DE MONTAGE

- Passez avec précaution la plaque de serrage (Article 2) autour du pied de la béquille latérale avec les fraises vers le haut.
- Prenez la plaque de montage en aluminium usinée (article 1) et fixez-la à la base de la béquille latérale par le dessous.
- Enserrez les deux plaques ensemble autour du pied de la béquille latérale.
- Appliquez une petite quantité (une goutte) de frein-filet sur l'extrémité filetée de chaque boulon à tête fraisée (article 4).
- Montez les quatre boulons (article 4) à travers la plaque de serrage et dans la plaque de montage, en serrant solidement les deux plaques ensemble au pied de la béquille latérale comme indiqué sur le schéma éclaté.
- Serrez tous les boulons uniformément et assurez-vous que la béquille est dégagée du bras oscillant et de la chaîne lorsqu'elle est en position relevée.
- En cas d'installation sur des supports usagés plus anciens et usés, la bande de mousse autocollante (article 4) doit être coupée et placée dans la plaque de base pour assurer un ajustement serré.

MONTAGE DU SUPPORT DE BUTÉE DE BUMP

- En raison des changements de longueur de béquille latérale sur la Pan America, un support d'extension de butée de béquille latérale peut être nécessaire pour que le patin de béquille dégage le bloc moteur.
- Présentez le support de butée d'arrêt jusqu'au carter du moteur côté gauche, où vous trouverez un trou fileté vide. (Photo 1)
- Poussez le boulon à tête fraisée M6 (article 5) à travers le support de butée (article 3) et serrez, l'ensemble doit ressembler à la photo 2.

ISSUE 1 - 27/07/2022 (TB)

CONSUMER NOTICE

The catalogue description and any exhibition of samples are only broad indications of the Products and R&G may make design changes which do not diminish their performance or visual appeal and supplying them in such state shall conform to the order. The Buyer acknowledges no representation or warranty (other than as to title) has been given or will apply to the Products other than those in R&G's order or confirmation and the Buyer confirms it has chosen the Products as being of merchantable quality and suitable for its particular purposes. Where R&G fits the Products or undertakes other services it shall exercise reasonable skill and care and rectify any fault free of charge unless the workmanship has been disturbed. The Buyer is responsible for ensuring that the warranty on the motorcycle is not affected by the fitting of the Products. On return of any defective Products R&G shall at its option either supply a replacement or refund the purchase money but shall not be liable if the Products have been modified or used or maintained otherwise than in accordance with R&G's or manufacturer's instructions and good engineering practice or if the defect arises from accident or neglect. Other than identified above and subject to R&G not limiting its liability for causing death and personal injury, it shall not be liable for indirect or consequential loss and otherwise its liability shall be limited to the amounts paid by the Buyer for the Products or the fitting or service concerned. These terms do not affect the Buyer's statutory rights.

R&G RACING RETURNS POLICY (NON-FAULTY GOODS)

Returns must be pre-authorized (if not pre-authorized the return will be rejected). Goods may only be returned direct to us if they were purchased direct from us (customer must prove if necessary). Otherwise to be returned to original vendor. Goods must be in re-sellable condition, in the opinion of R&G Racing. All returns are subject to a 25% restocking and handling fee (25% of the gross value exc. P&P – at the prevailing price at time of purchase). The customer must pay any and all carriage charges. No returns of discontinued products, unless within 14 days of purchase. This policy does not affect your statutory rights and does not refer to faulty goods.

R&G

Unit 1, Shelley's Lane, East Worldham, Alton, Hampshire, GU34 3AQ

Tel: +44 (0)1420 89007 Fax: +44 (0)1420 87301 www.rg-racing.com Email: info@rg-racing.com