

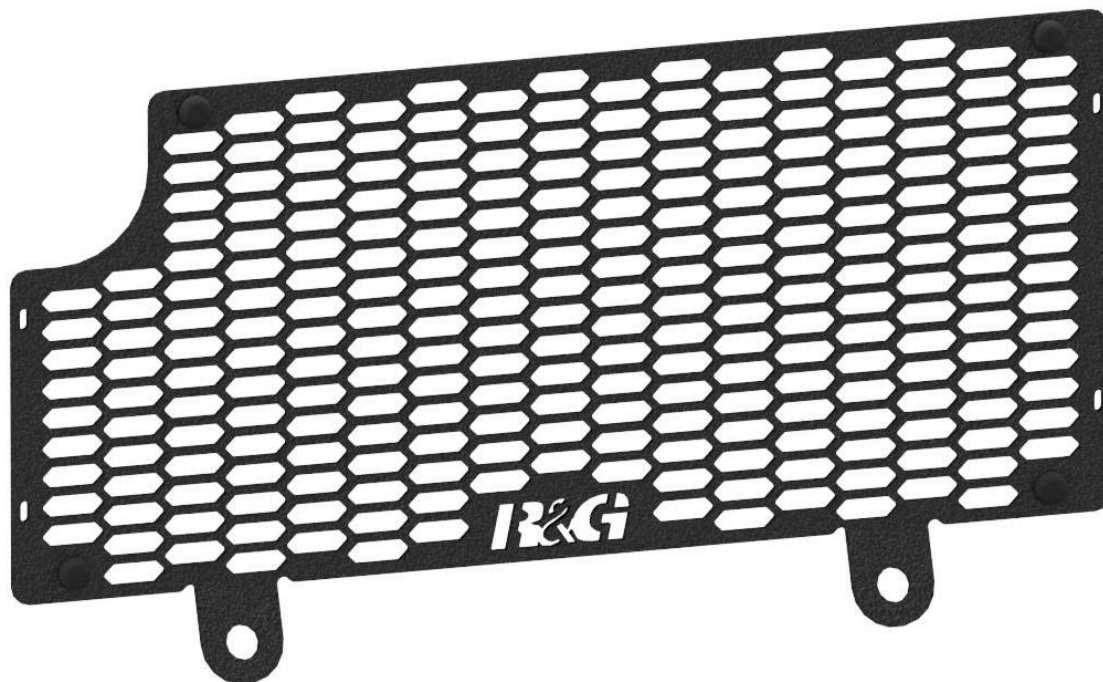

FITTING INSTRUCTIONS FOR OCG0058PRO
OIL COOLER GUARD



THIS KIT CONTAINS THE ITEMS PICTURED AND LABELLED OVER PAGE.

SOME PARTS MAY BE SHOWN FOR CLARITY OF INSTRUCTIONS ONLY.

DO NOT PROCEED UNTIL YOU ARE SURE ALL PARTS ARE PRESENT.

PLEASE READ ALL INSTRUCTIONS BEFORE PROCEEDING.

**IF IN ANY DOUBT WHEN FITTING OUR PRODUCTS, CONSULT ONE OF OUR DEALERS
OR HAVE FITTED BY A QUALIFIED TECHNICIAN.**

PLEASE NOTE THAT THE WAY THE KIT IS PACKED DOES NOT NECESSARILY REPRESENT THE WAY OF
MOUNTING TO THE BIKE.

IN THE EVENT OF RUBBER WASHERS BEING USED TO HOLD COMPONENTS ONTO BOLTS,
THESE RUBBER WASHERS CAN BE THROWN AWAY.

DIGITAL COPIES OF THESE INSTRUCTIONS ARE AVAILABLE FROM:

WWW.RG-RACING.COM



<u>TOOLS REQUIRED</u>	<u>GENERAL TORQUE SETTINGS</u>
<ul style="list-style-type: none"> • Allen key set to include 4 & 5mm A/F. <ul style="list-style-type: none"> • 10mm spanner or socket. • Phillips and flat bladed driver. <ul style="list-style-type: none"> • Cable cutters. 	M4 BOLT = 8Nm M5 BOLT = 12Nm M6 BOLT = 15Nm M8 BOLT = 20Nm M10 BOLT = 40Nm M12 BOLT = 40Nm

LEGEND

ITEM NO.	DESCRIPTION	QTY
ITEM 1	OIL COOLER GUARD (OCG0058)	1
ITEM 2	RB0015 RUBBER BUNG	4
ITEM 3	2.5mm CABLE TIES	8



PICTURE 1



PICTURE 2

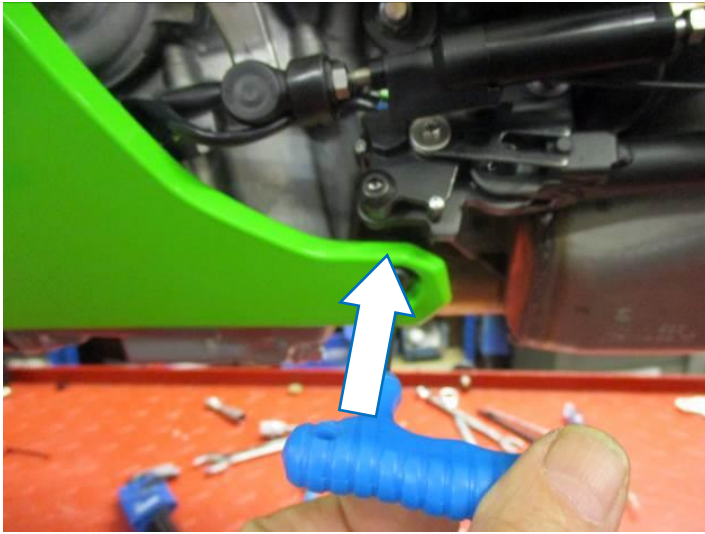

PICTURE 3

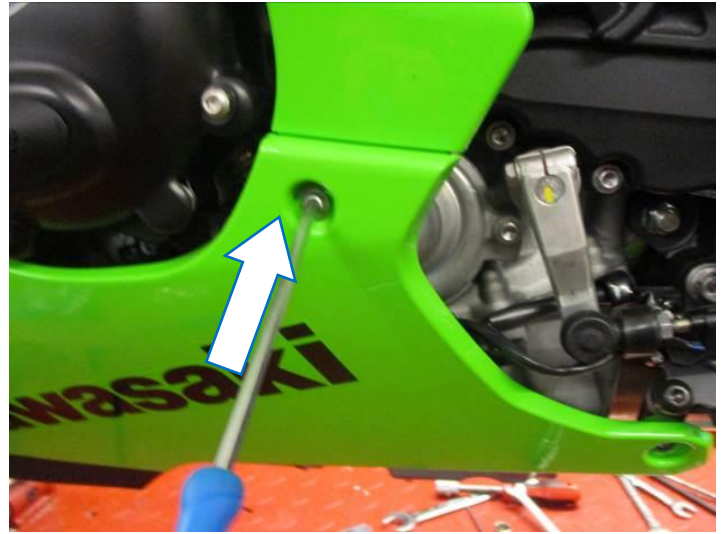

PICTURE 4



PICTURE 5



PICTURE 6

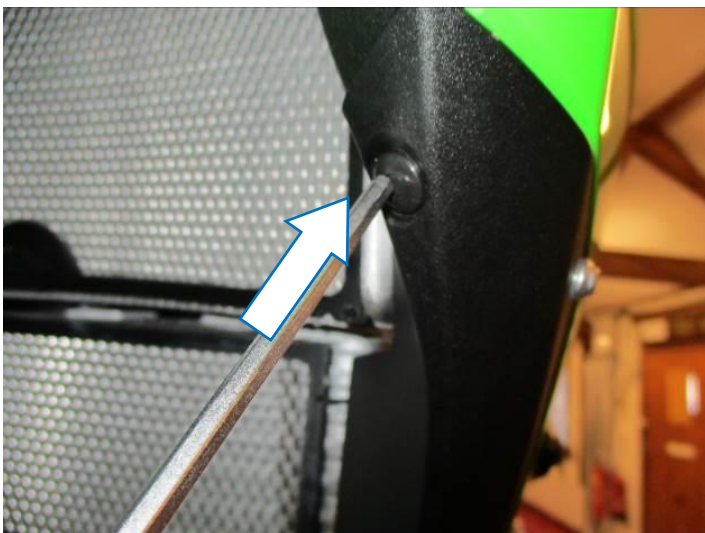

PICTURE 7

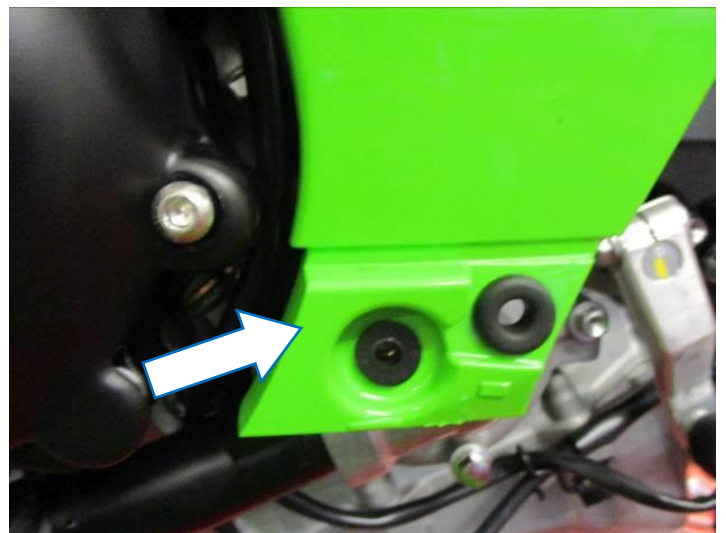

PICTURE 8

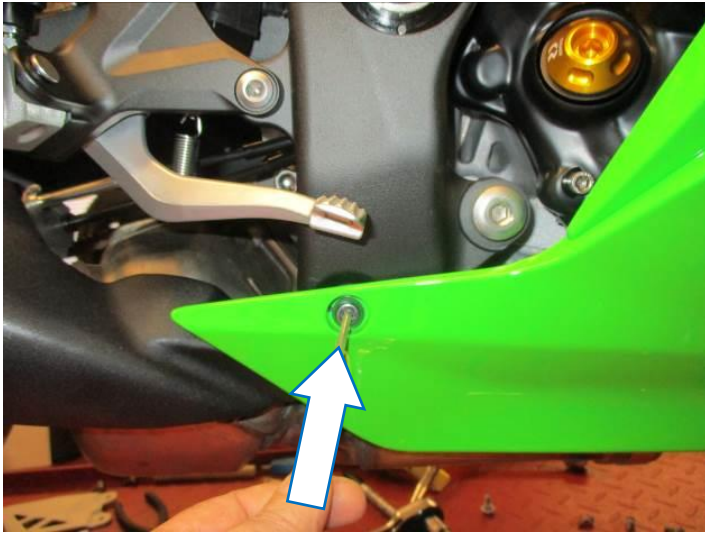

PICTURE 9



PICTURE 10



PICTURE 11



PICTURE 12



PICTURE 13

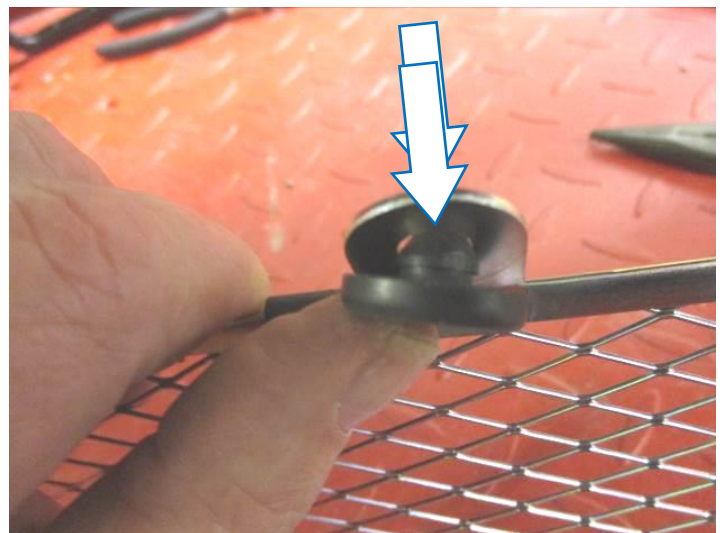

PICTURE 14

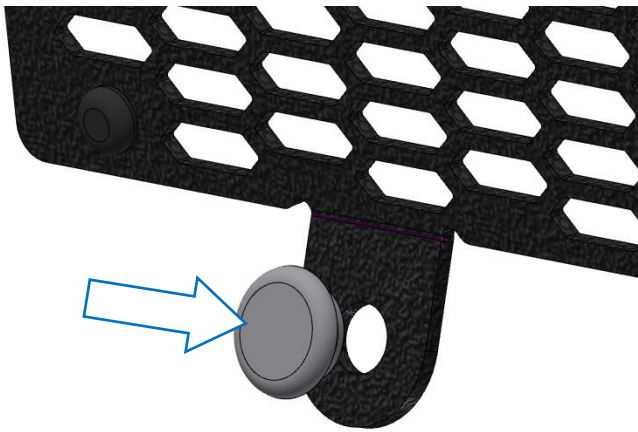

PICTURE 15

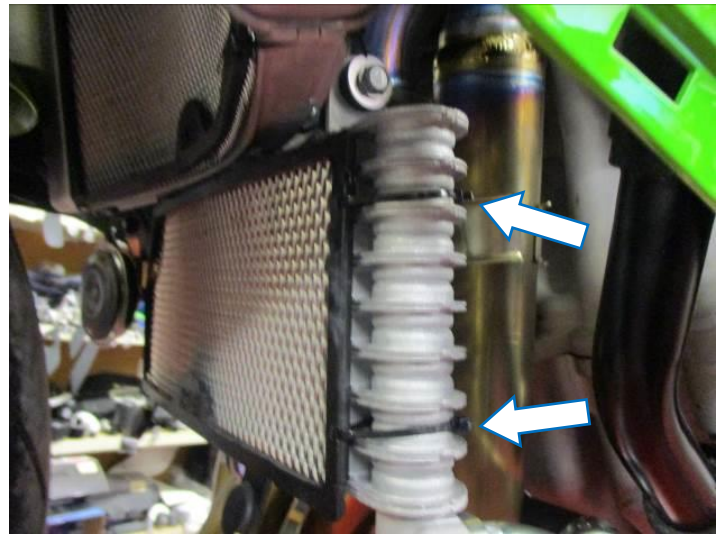

PICTURE 16

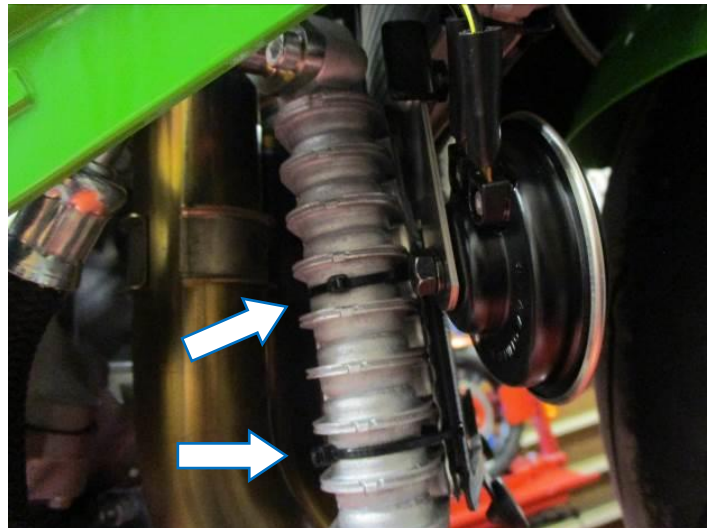

PICTURE 17

FITTING INSTRUCTIONS

Near side (left side as you sit on the motorcycle)

- Remove the three plastic rivets arrowed in **pictures 1 and 2**.
- Remove the five bolts arrowed in **pictures 3, 4, 5, 6 and 7**.
- Carefully remove the lower fairing.

Off side (right side as you sit on the motorcycle)

- Remove the five bolts arrowed in **pictures 9, 10, 11, 12 and 13**.
- Carefully remove the lower fairing.

Fitting the R&G oil cooler guard

- To fit the oil cooler guard to the bike, first fit the rubber bungs provided into the 4 holes in the corners of the guard, they will sit between the oil cooler and the oil cooler guard.
- Remove the original oil cooler guard by carefully pulling the guard away from the oil cooler releasing the spring clips from the sides of the oil cooler.



- Remove both the rubber pads as shown in **picture 14** and fit to the new oil cooler guard as shown in **picture 15**.
- Use 4 of the supplied cable ties (**item 3**) to secure the guard into position ensuring to pass the cable ties around the oil cooler frame and not the cooling matrix as shown below in **pictures 16 & 17**.
- Refit both fairings as original.

ISSUE 1 19/02/2024 (DM)

CONSUMER NOTICE

The catalogue description and any exhibition of samples are only broad indications of the Products and R&G may make design changes which do not diminish their performance or visual appeal and supplying them in such state shall conform to the order. The Buyer acknowledges no representation or warranty (other than as to title) has been given or will apply to the Products other than those in R&G's order or confirmation and the Buyer confirms it has chosen the Products as being of merchantable quality and suitable for its particular purposes. Where R&G fits the Products or undertakes other services it shall exercise reasonable skill and care and rectify any fault free of charge unless the workmanship has been disturbed. The Buyer is responsible for ensuring that the warranty on the motorcycle is not affected by the fitting of the Products. On return of any defective Products R&G shall at its option either supply a replacement or refund the purchase money but shall not be liable if the Products have been modified or used or maintained otherwise than in accordance with R&G's or manufacturer's instructions and good engineering practice or if the defect arises from accident or neglect. Other than identified above and subject to R&G not limiting its liability for causing death and personal injury, it shall not be liable for indirect or consequential loss and otherwise its liability shall be limited to the amounts paid by the Buyer for the Products or the fitting or service concerned. These terms do not affect the Buyer's statutory rights.

R&G RETURNS POLICY (NON-FAULTY GOODS)

Returns must be pre-authorized (if not pre-authorized the return will be rejected). Goods may only be returned direct to us if they were purchased direct from us (customer must prove if necessary). Otherwise to be returned to original vendor. Goods must be in re-sellable condition, in the opinion of R&G. All returns are subject to a 25% restocking and handling fee (25% of the gross value exc. P&P – at the prevailing price at time of purchase). The customer must pay any and all carriage charges. No returns of discontinued products, unless within 14 days of purchase. This policy does not affect your statutory rights and does not refer to faulty goods.

NOTICE DE MONTAGE POUR OCG0058PRO **PROTECTION REFROIDISSEUR D'HUILE**

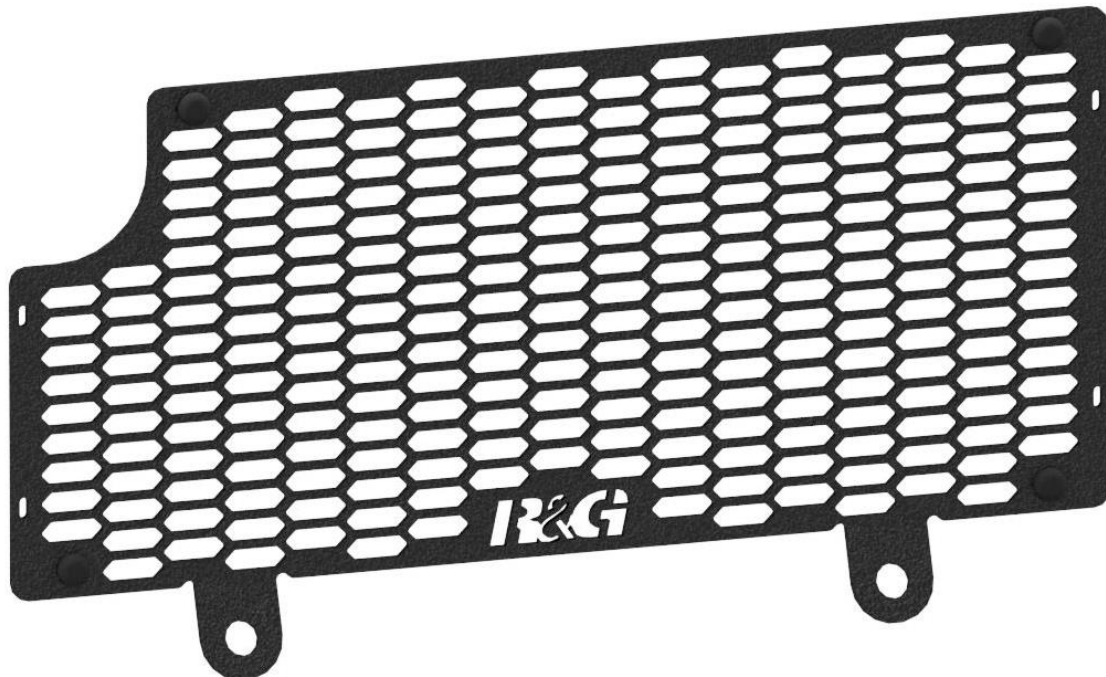

CE KIT CONTIENT LES ARTICLES ILLUSTRES ET ETIQUETES SUR LA PAGE.

R&G

Unit 1, Shelley's Lane, East Worldham, Alton, Hampshire, GU34 3AQ
Tel: +44 (0)1420 89007 www.rg-racing.com Email: info@rg-racing.com



CERTAINES PARTIES PEUVENT ETRE PRESENTES UNIQUEMENT POUR LA CLARTE DES INSTRUCTIONS.
NE PAS PROCEDER AU MONTAGE TANT QUE VOUS N'ETES PAS SUR QUE TOUTES LES PIECES SOIENT
PRESENTES.

VEUILLEZ LIRE TOUTES LES INSTRUCTIONS AVANT DE CONTINUER.

**EN CAS DE DOUTE LORS DU MONTAGE DE NOS PRODUITS, CONSULTEZ UN DE NOS
REVENDEURS OU FAITES APPEL A UN TECHNICIEN QUALIFIÉ.**

VEUILLEZ NOTER QUE LA FAÇON DONT LE KIT EST EMBALLE NE REPRESENTE PAS NECESSAIREMENT LA
MANIERE DE LE MONTER SUR LA MOTO.

SI DES RONDELLES EN CAOUTCHOUC SONT UTILISEES POUR MAINTENIR LES COMPOSANTS SUR LES
BOULONS, ELLES PEUVENT ETRE JETEES.

NOTICE DISPONIBLE AU TELECHARGEMENT SUR :

WWW.RG-RACING.COM

<u>OUTILS REQUIS</u>	<u>VALEURS DE SERRAGE</u>
<ul style="list-style-type: none"> • Clés Allen 4mm & 5mm • Clé à molette 10mm. • Tournevis plat et cruciforme. <ul style="list-style-type: none"> • Coupe câble. 	M4 BOULON = 8Nm M5 BOULON = 12Nm M6 BOULON = 15Nm M8 BOULON = 20Nm M10 BOULON = 40Nm M12 BOULON = 40Nm

LÉGENDE

ARTICLE NO.	DESCRIPTION	QTÉ
ARTICLE 1	PROTECTION REFROIDISSEUR D'HUILE (OCG0058)	1
ARTICLE 2	RB0015 OEILLET EN CAOUTCHOUC	4
ARTICLE 3	2.5mm COLLIERS DE SERRAGE	8



PHOTO 1



PHOTO 2



PHOTO 3



PHOTO 4



PHOTO 5

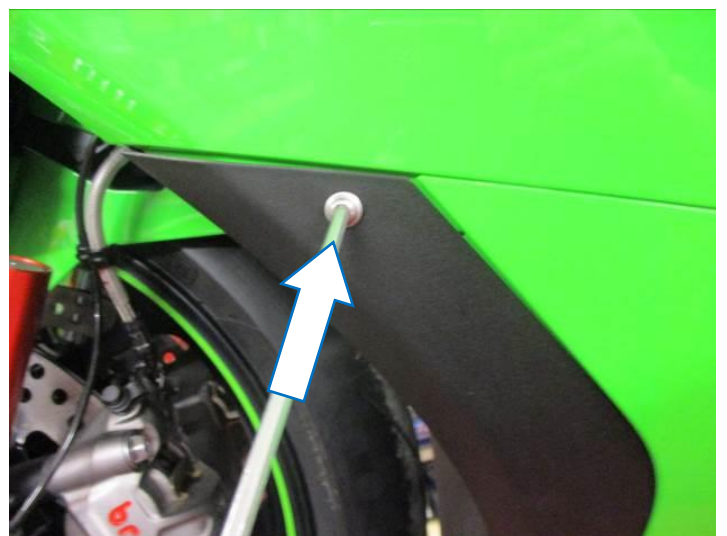

PHOTO 6

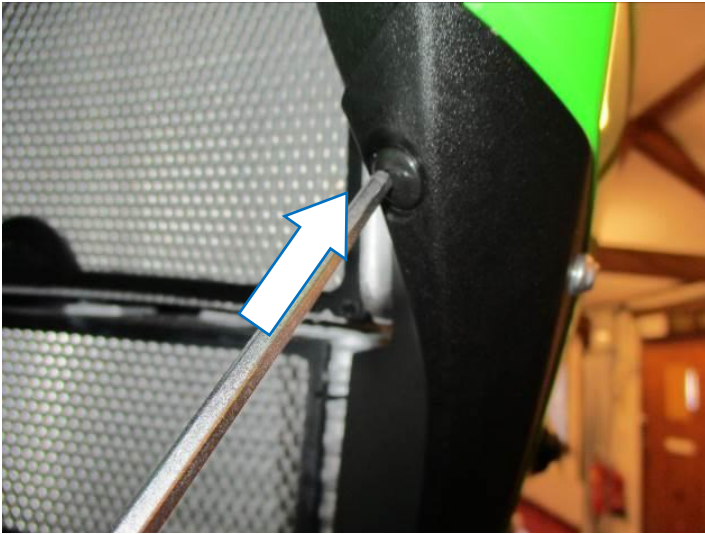

PHOTO 7

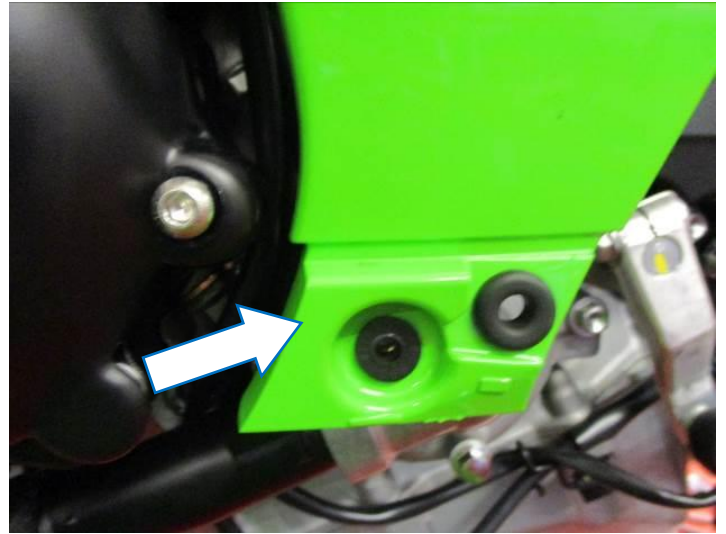

PHOTO 8



PHOTO 9



PHOTO 10

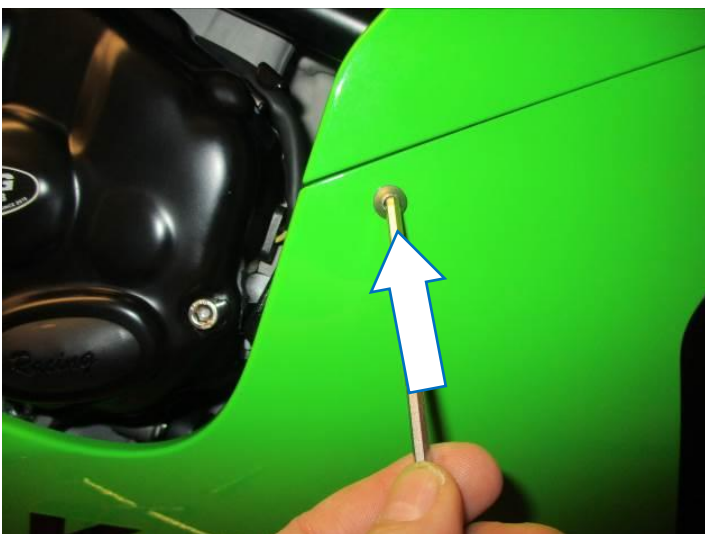

PHOTO 11



PHOTO 12



PHOTO 13

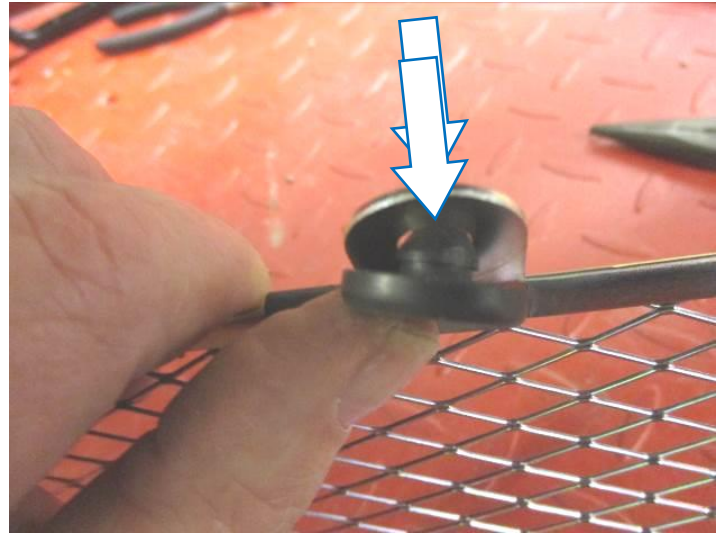

PHOTO 14

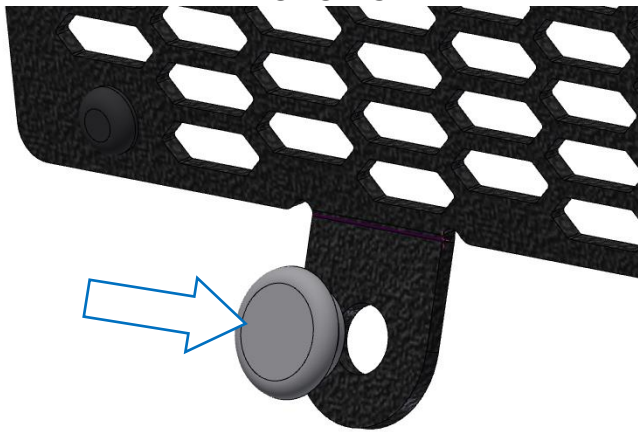

PHOTO 15

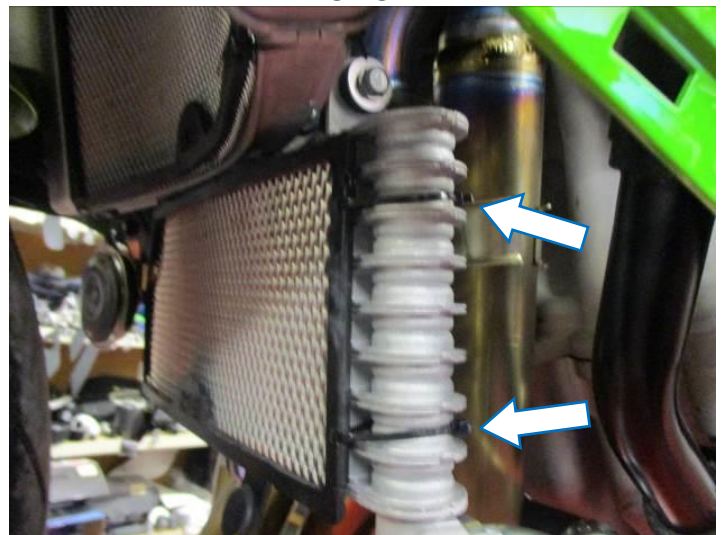

PHOTO 16

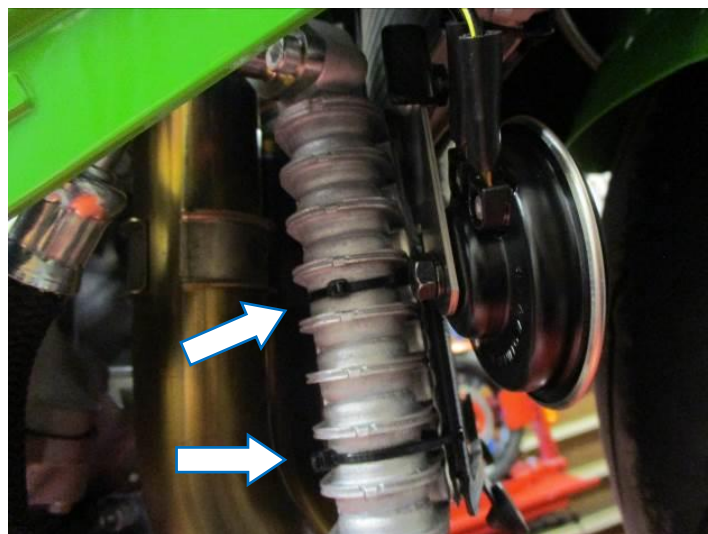

PHOTO 17



NOTICE DE MONTAGE

Côté proche (côté gauche lorsque vous êtes assis sur la moto)

- Retirez les trois rivets en plastique fléchés sur les photos 1 et 2.
- Retirez les cinq boulons fléchés sur les photos 3, 4, 5, 6 et 7.
- Retirez délicatement le carénage inférieur.

Autre côté (côté droit lorsque vous êtes assis sur la moto)

- Retirez les cinq boulons fléchés sur les photos 9, 10, 11, 12 et 13.
- Retirez délicatement le carénage inférieur.

Montage de la protection du refroidisseur d'huile R&G

- Pour monter la protection du refroidisseur d'huile sur la moto, insérez d'abord les bouchons en caoutchouc fournis dans les 4 trous dans les coins de la protection, ils se placeront entre le refroidisseur d'huile et la protection du refroidisseur d'huile.
- Retirez la protection du refroidisseur d'huile d'origine en retirant soigneusement la protection du refroidisseur d'huile en libérant les clips à ressort des côtés du refroidisseur d'huile.
- Retirez les deux patins en caoutchouc comme indiqué sur la photo 14 et installez-les sur la nouvelle protection du refroidisseur d'huile comme indiqué sur la photo 15.
- Utilisez 4 des attaches de câble fournies (article 3) pour fixer la protection en position en vous assurant de passer les attaches de câble autour du cadre du refroidisseur d'huile et non de la matrice de refroidissement comme indiqué ci-dessous sur les photos 16 et 17.
- Remonter les deux carénages comme d'origine.

ISSUE 1 19/02/2024 (DM)

CONSUMER NOTICE

The catalogue description and any exhibition of samples are only broad indications of the Products and R&G may make design changes which do not diminish their performance or visual appeal and supplying them in such state shall conform to the order. The Buyer acknowledges no representation or warranty (other than as to title) has been given or will apply to the Products other than those in R&G's order or confirmation and the Buyer confirms it has chosen the Products as being of merchantable quality and suitable for its particular purposes. Where R&G fits the Products or undertakes other services it shall exercise reasonable skill and care and rectify any fault free of charge unless the workmanship has been disturbed. The Buyer is responsible for ensuring that the warranty on the motorcycle is not affected by the fitting of the Products. On return of any defective Products R&G shall at its option either supply a replacement or refund the purchase money but shall not be liable if the Products have been modified or used or maintained otherwise than in accordance with R&G's or manufacturer's instructions and good engineering practice or if the defect arises from accident or neglect. Other than identified above and subject to R&G not limiting its liability for causing death and personal injury, it shall not be liable for indirect or consequential loss and otherwise its liability shall be limited to the amounts paid by the Buyer for the Products or the fitting or service concerned. These terms do not affect the Buyer's statutory rights.

R&G RETURNS POLICY (NON-FAULTY GOODS)

Returns must be pre-authorized (if not pre-authorized the return will be rejected). Goods may only be returned direct to us if they were purchased direct from us (customer must prove if necessary). Otherwise to be returned to original vendor. Goods must be in re-sellable condition, in the opinion of R&G. All returns are subject to a 25% restocking and handling fee (25% of the gross value exc. P&P – at the prevailing price at time of purchase). The customer must pay any and all carriage charges. No returns of discontinued products, unless within 14 days of purchase. This policy does not affect your statutory rights and does not refer to faulty goods.

R&G

Unit 1, Shelley's Lane, East Worldham, Alton, Hampshire, GU34 3AQ
Tel: +44 (0)1420 89007 www.rg-racing.com Email: info@rg-racing.com