



**FITTING INSTRUCTIONS FOR LP0042BK LICENCE PLATE BRACKET  
FOR HONDA CBR600 RR 2007-**



**THIS KIT CONTAINS THE ITEMS PICTURED AND LABELLED OVER PAGE.**

SOME PARTS MAY BE SHOWN FOR CLARITY OF INSTRUCTIONS ONLY.

DO NOT PROCEED UNTIL YOU ARE SURE ALL PARTS ARE PRESENT.

**PLEASE READ ALL INSTRUCTIONS BEFORE PROCEEDING.**

**IF IN ANY DOUBT WHEN FITTING OUR PRODUCTS, CONSULT ONE OF OUR DEALERS  
OR HAVE FITTED BY A QUALIFIED TECHNICIAN.**

PLEASE NOTE THAT THE WAY THE KIT IS PACKED DOES NOT NECESSARILY REPRESENT THE WAY OF  
MOUNTING TO THE BIKE.

IN THE EVENT OF RUBBER WASHERS BEING USED TO HOLD COMPONENTS ONTO BOLTS,  
THESE RUBBER WASHERS CAN BE THROWN AWAY.

**DIGITAL COPIES OF THESE INSTRUCTIONS ARE AVAILABLE FROM:**

[WWW.RG-RACING.COM](http://WWW.RG-RACING.COM)

R&G

Unit 1, Shelley's Lane, East Worldham, Alton, Hampshire, GU34 3AQ

Tel: +44 (0)1420 89007 Fax: +44 (0)1420 87301 [www.rg-racing.com](http://www.rg-racing.com) Email: [info@rg-racing.com](mailto:info@rg-racing.com)



<b><u>TOOLS REQUIRED</u></b>	<b><u>GENERAL TORQUE SETTINGS</u></b>
<ul style="list-style-type: none"> <li>• set of metric Allen keys.</li> <li>• Metric socket set.</li> <li>• Cable cutters/pliers.</li> </ul>	<p>M4 BOLT = 8Nm</p> <p>M5 BOLT = 12Nm</p> <p>M6 BOLT = 15Nm</p> <p>M8 BOLT = 20Nm</p> <p>M10 BOLT = 40Nm</p> <p>M12 BOLT = 40Nm</p>

### **LEGEND**

<b>ITEM NO.</b>	<b>DESCRIPTION</b>	<b>QTY</b>
ITEM 1	LICENCE PLATE BRACKET (TB0042)	1
ITEM 2	M6 NYLOC NUTS	2
ITEM 3	M6 LARGE WASHERS	4
ITEM 4	M6 x 20mm LONG BUTTON HEAD BOLTS	4
ITEM 5	M6 STANDARD WASHERS	2
ITEM 6	M6 x 15mm LONG BUTTON HEAD BOLTS	2
ITEM 7	COVER PLATE (TB0042 PART 2)	1
ITEM 8	REAR LIGHT SHROUD (LA0003 SHROUD)	1
ITEM 9	REAR LIGHT/LICENCE PLATE ILLUMINATOR ASSEMBLY	1
ITEM 10	150mm LENGTH OF HEATSHRINK	3
ITEM 11	SCOTCH BLOCK CONNECTORS	3
ITEM 12	REFLECTOR (REFL 3)	1

R&G

Unit 1, Shelley's Lane, East Worldham, Alton, Hampshire, GU34 3AQ

Tel: +44 (0)1420 89007 Fax: +44 (0)1420 87301 [www.rg-racing.com](http://www.rg-racing.com) Email: [info@rg-racing.com](mailto:info@rg-racing.com)

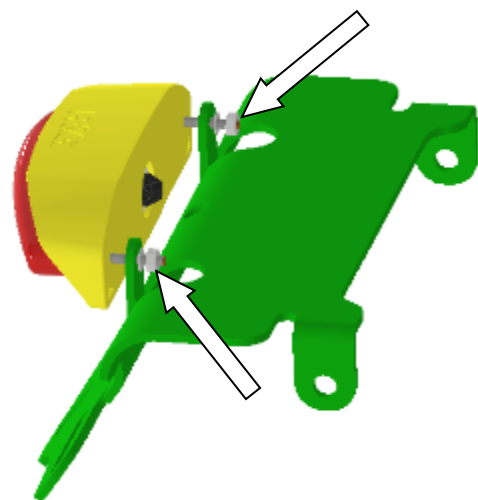
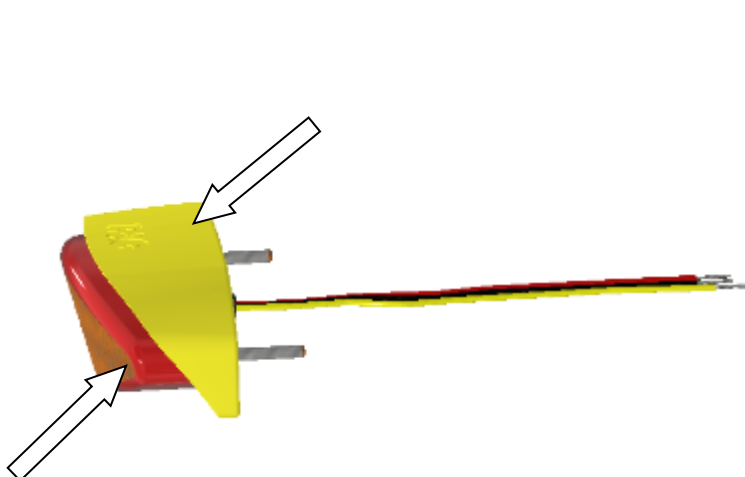
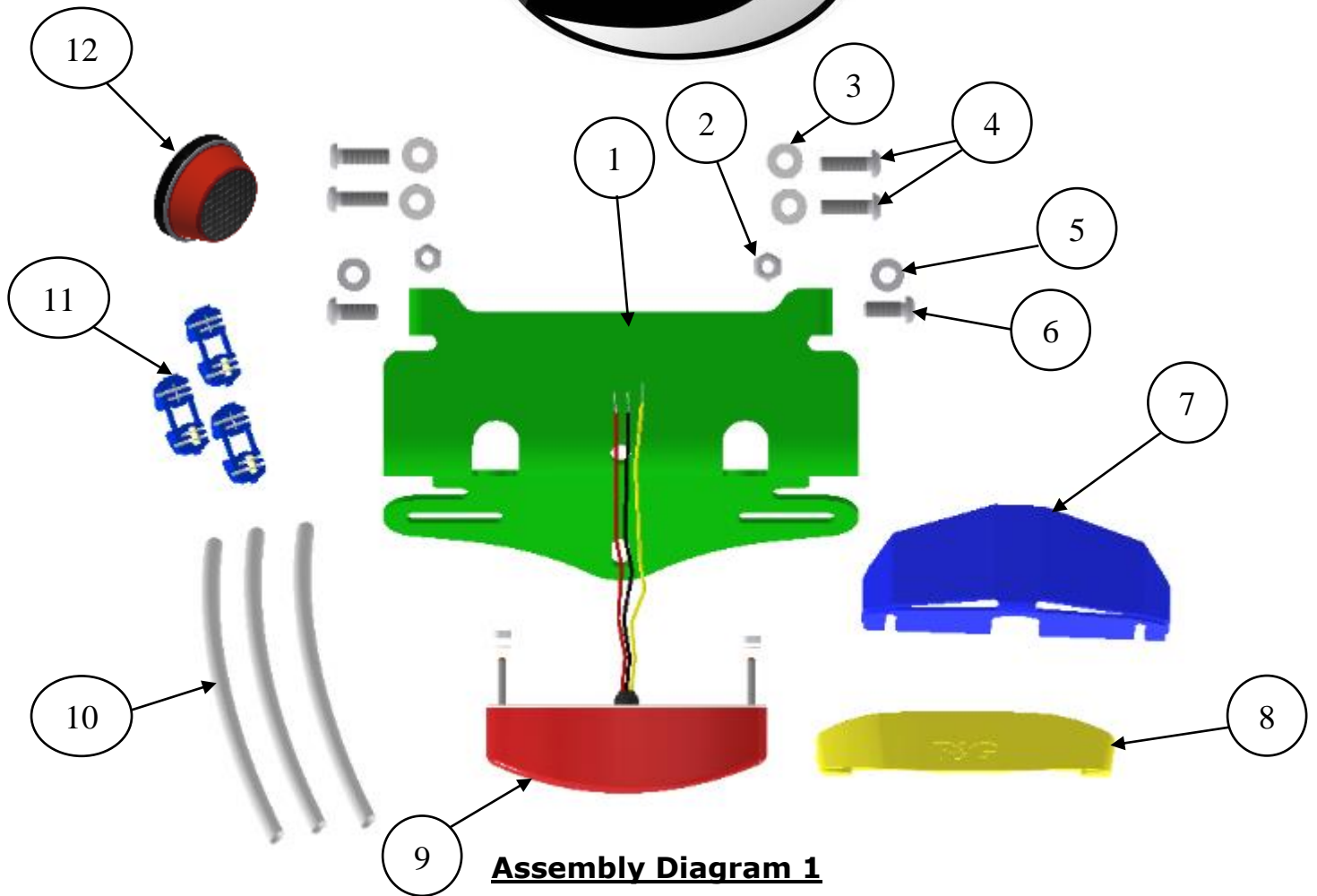

PICTURE 1

PICTURE 2

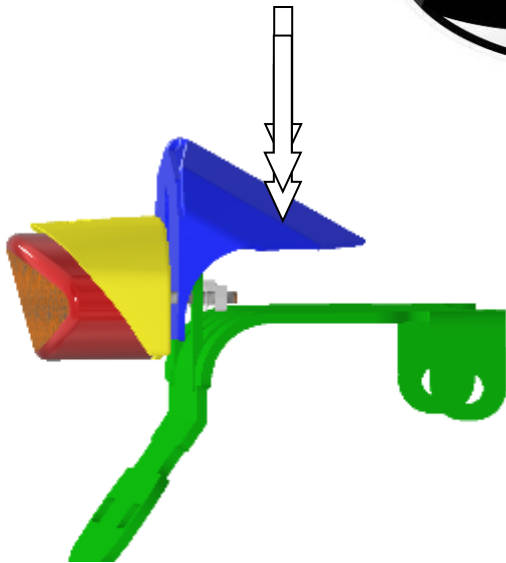

PICTURE 3

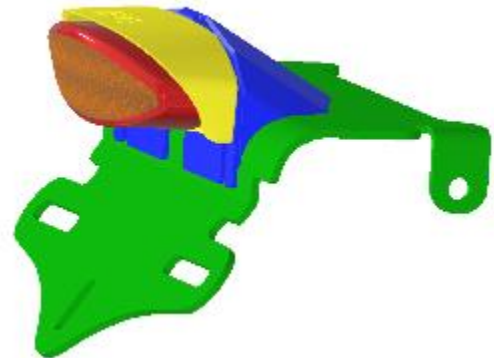

PICTURE 4

### **FITTING INSTRUCTIONS**

- Remove both seats.
- Remove rear seat cowling.
- Disconnect wiring to original number plate unit.
- Undo the four bolts holding the original number plate unit to the subframe.
- Remove OEM indicators and rear light unit from original number plate unit.
- The OEM tail unit should be in three parts i.e.; two sides and one number plate hanger.
- Replace both side assemblies to sub-frame using longer supplied button head bolts and washers (**items 3 and 4**) but leave all bolts loose.
- Fit OEM or after-market indicators (we recommend R&G micro indicators - product code RG370) to OEM sides
- Fit the shroud (**item 8**) to the new rear light (**item 9**) as shown in **picture 1**.
- Place this assembly through the holes in the licence plate bracket (**item 1**) as shown in **picture 2**.
- Place the M3 nuts and washers onto the exposed threads as shown in **picture 2** (do not tighten at this stage) and feed the wires through the central hole.
- Please protect the wire with a length of heat shrink (**item 10**).
- Place the cover plate (**item 7**) between the shroud and the bracket as shown in **picture 3** and push down to the bracket as shown in **picture 4** and tighten the nuts.
- Offer new tail-tidy unit up between side panels.
- Using shorter button head bolts and smaller washers supplied (**items 5 and 6**) secure new tail-tidy to OEM sides using nyloc nuts supplied (**item 2**).
- Route indicator and new rear light wiring through clips provided as original.
- Reconnect indicator wiring, checking operation (Note: right side indicator has the ORANGE connector).
- Using scotch block connectors supplied (**item 11**), re-attach the rear light wiring (suggest cutting connector from OEM unit and splicing to R&G unit) as shown below.

New wires		OEM wires
Black	to	Black
Yellow	to	Black/White
Red	to	Black/Yellow

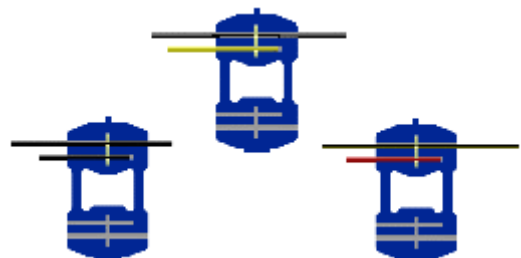

R&amp;G

Unit 1, Shelley's Lane, East Worldham, Alton, Hampshire, GU34 3AQ

Tel: +44 (0)1420 89007 Fax: +44 (0)1420 87301 [www.rg-racing.com](http://www.rg-racing.com) Email: [info@rg-racing.com](mailto:info@rg-racing.com)



- **IMPORTANT: IF FITTING A FULL-SIZE LICENCE PLATE AND PLACING IT FAR DOWN ON THE LICENCE PLATE HANGER, THERE IS A SMALL CHANCE OF THE LICENCE PLATE HITTING THE BACK WHEEL UNDER HEAVY LOAD AND OVER LARGE BUMPS IN THE ROAD. IT IS YOUR RESPONSIBILITY TO CHECK FOR THIS POSSIBILITY AND TAKE AVOIDING ACTION. FAILURE TO CHECK THIS COULD RESULT IN SERIOUS INJURY.**
- Recheck that wires cannot contact the exhaust silencer.
- Tighten all bolts securing tail-tidy to sub-frame.
- Refit rear cowling.
- Refit seats.
- Depending on local laws, attach enclosed reflector (**item 12**) in an appropriate location.
- Test the indicators and licence plate illuminator before riding.
- **Please test the indicators, rear light and licence plate illuminator before riding.**

ISSUE 2 22/10/2019 (NSY)

#### CONSUMER NOTICE

The catalogue description and any exhibition of samples are only broad indications of the Products and R&G may make design changes which do not diminish their performance or visual appeal and supplying them in such state shall conform to the order. The Buyer acknowledges no representation or warranty (other than as to title) has been given or will apply to the Products other than those in R&G's order or confirmation and the Buyer confirms it has chosen the Products as being of merchantable quality and suitable for its particular purposes. Where R&G fits the Products or undertakes other services it shall exercise reasonable skill and care and rectify any fault free of charge unless the workmanship has been disturbed. The Buyer is responsible for ensuring that the warranty on the motorcycle is not affected by the fitting of the Products. On return of any defective Products R&G shall at its option either supply a replacement or refund the purchase money but shall not be liable if the Products have been modified or used or maintained otherwise than in accordance with R&G's or manufacturer's instructions and good engineering practice or if the defect arises from accident or neglect. Other than identified above and subject to R&G not limiting its liability for causing death and personal injury, it shall not be liable for indirect or consequential loss and otherwise its liability shall be limited to the amounts paid by the Buyer for the Products or the fitting or service concerned. These terms do not affect the Buyer's statutory rights.

#### R&G RETURNS POLICY (NON-FAULTY GOODS)

Returns must be pre-authorized (if not pre-authorized the return will be rejected). Goods may only be returned direct to us if they were purchased direct from us (customer must prove if necessary). Otherwise to be returned to original vendor. Goods must be in re-sellable condition, in the opinion of R&G. All returns are subject to a 25% restocking and handling fee (25% of the gross value exc. P&P – at the prevailing price at time of purchase). The customer must pay any and all carriage charges. No returns of discontinued products, unless within 14 days of purchase. This policy does not affect your statutory rights and does not refer to faulty goods.

R&G

Unit 1, Shelley's Lane, East Worldham, Alton, Hampshire, GU34 3AQ

Tel: +44 (0)1420 89007 Fax: +44 (0)1420 87301 [www.rg-racing.com](http://www.rg-racing.com) Email: [info@rg-racing.com](mailto:info@rg-racing.com)



**NOTICE DE MONTAGE POUR LP0042BK SUPPORT DE PLAQUE**  
**POUR HONDA CBR600 RR 20007-**



**LE KIT CONTIENT LES ARTICLES EN PHOTO ET ETIQUETTES SUR LA PAGE**

LES PARTIES PRÉSENTÉES PEUVENT ÊTRE UNIQUEMENT REPRESENTATIVES POUR LA CLARTE DES  
INSTRUCTIONS

NE PAS PROCÉDER AU MONTAGE AVANT DE VOUS ÊTRE ASSURÉ QUE TOUTES LES PIÈCES SOIENT PRÉSENTES.

**SVP, LIRE L'ENSEMBLE DE LA NOTICE AVANT DE PROCÉDER AU MONTAGE.**

**EN CAS DE DOUTE LORS DU MONTAGE, CONSULTEZ UN DE NOS REVENDEURS, OU  
FAITES EFFECTUER LE MONTAGE PAR UN TECHNICIEN QUALIFIÉ.**

LA FAÇON DONT LE KIT EST EMBALLÉ NE CORRESPOND PAS FORCÉMENT À LA FAÇON DE MONTER LES  
PIÈCES SUR LA MOTO .

NOTEZ QUE SI LES KITS SONT EMBALLÉS AVEC DES RONDELLES EN CAOUTCHOUC SERVANT À TENIR LES  
COMPOSANTS, CES RONDELLES DOIVENT ÊTRE JETÉES.

**NOTICE DISPONIBLE AU TÉLÉCHARGEMENT SUR : [WWW.RG-RACING.COM](http://WWW.RG-RACING.COM)**

R&G

Unit 1, Shelley's Lane, East Worldham, Alton, Hampshire, GU34 3AQ

Tel: +44 (0)1420 89007 Fax: +44 (0)1420 87301 [www.rg-racing.com](http://www.rg-racing.com) Email: [info@rg-racing.com](mailto:info@rg-racing.com)



<b><u>OUTILS REQUIS</u></b>	<b><u>VALEURS DE SERRAGE</u></b>
<ul style="list-style-type: none"> <li>• Clés Allen</li> <li>• Clé à cliquet</li> <li>• Coupe câble.</li> </ul>	M4 BOULON = 8Nm M5 BOULON = 12Nm M6 BOULON = 15Nm M8 BOULON = 20Nm M10 BOULON = 40Nm M12 BOULON = 40Nm

### **LEGENDE**

<b>ARTICLE NO.</b>	<b>DESCRIPTION</b>	<b>QTE</b>
ARTICLE 1	SUPPORT DE PLAQUE (TB0042)	1
ARTICLE 2	M6 ECROU	2
ARTICLE 3	M6 RONDELLES	4
ARTICLE 4	M6 x 20mm BOULONS	4
ARTICLE 5	M6 RONDELLES	2
ARTICLE 6	M6 x 15mm BOULONS	2
ARTICLE 7	CACHE PLAQUE (TB0042 PARTIE 2)	1
ARTICLE 8	LINCEUL DE FEU ARRIERE (LA0003 SHROUD)	1
ARTICLE 9	ASSEMBLAGE DE FEU DE PLAQUE / FEU ARRIERE	1
ARTICLE 10	150mm MANCHON THERMO RETRACTABLE	3
ARTICLE 11	CONNECTEURS DE BLOC SCOTHE	3
ARTICLE 12	REFLECTEUR (REFL 3)	1

R&G

Unit 1, Shelley's Lane, East Worldham, Alton, Hampshire, GU34 3AQ

Tel: +44 (0)1420 89007 Fax: +44 (0)1420 87301 [www.rg-racing.com](http://www.rg-racing.com) Email: [info@rg-racing.com](mailto:info@rg-racing.com)

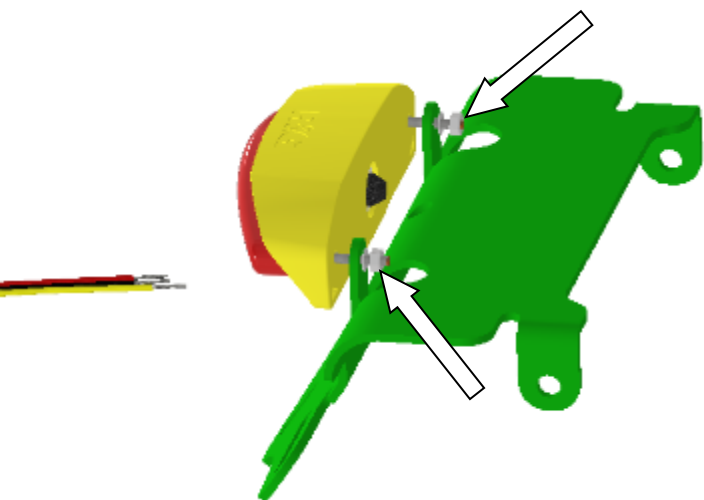
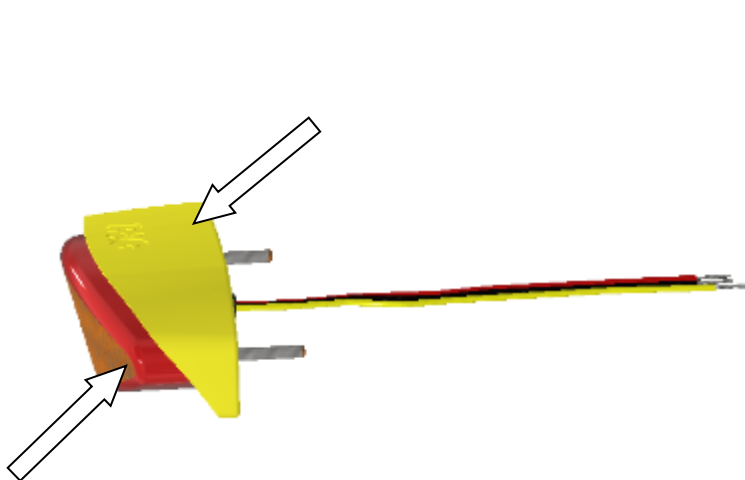
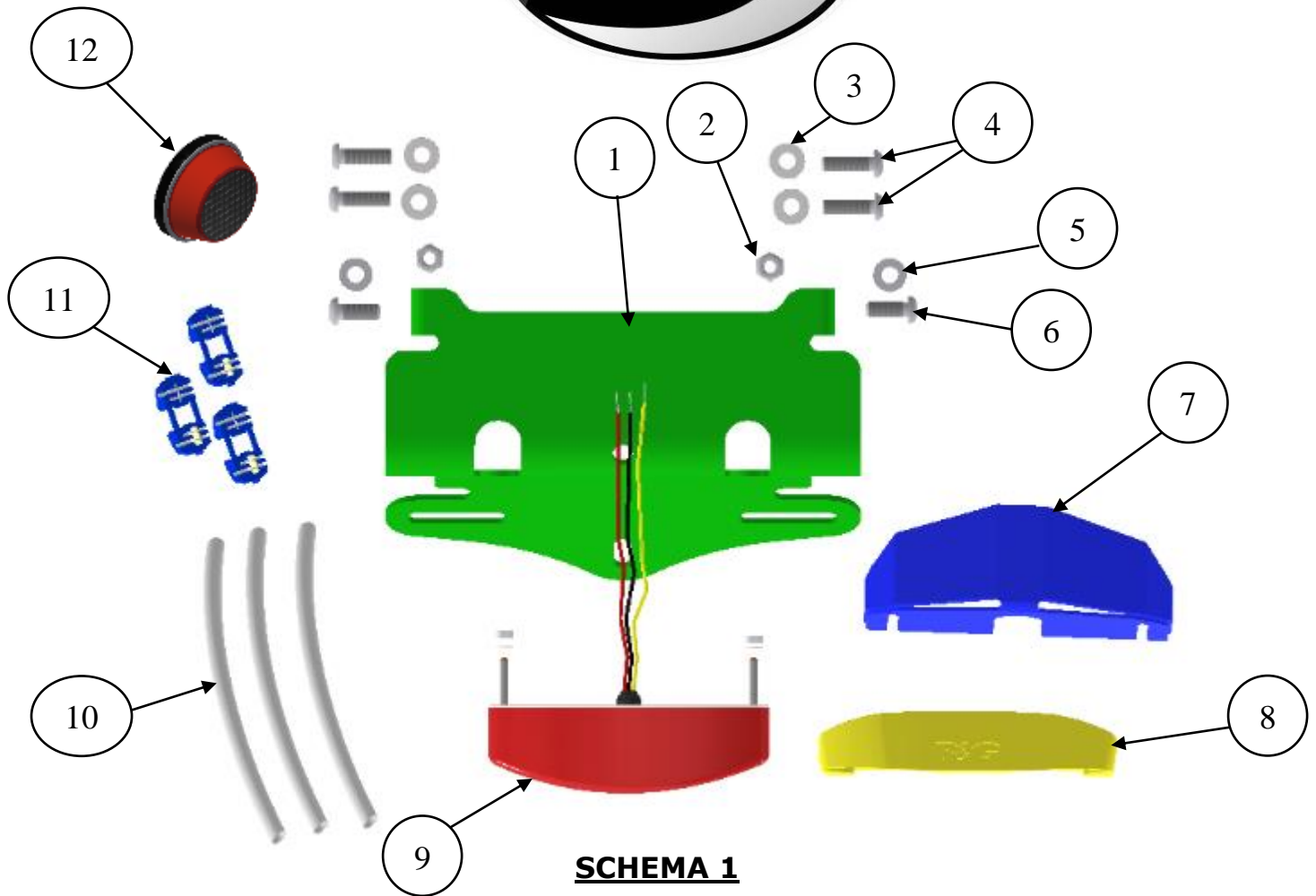



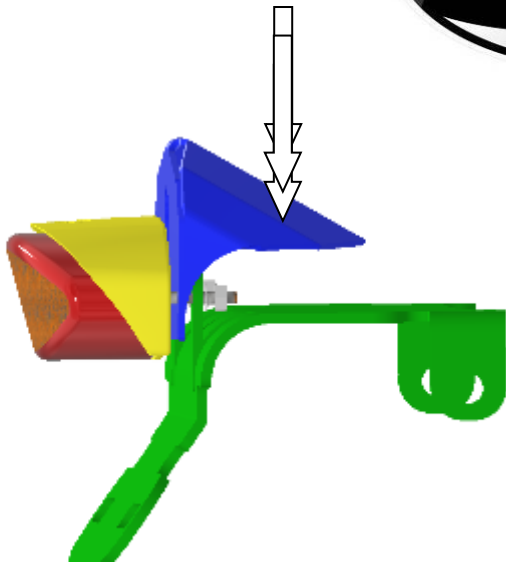

PHOTO 3

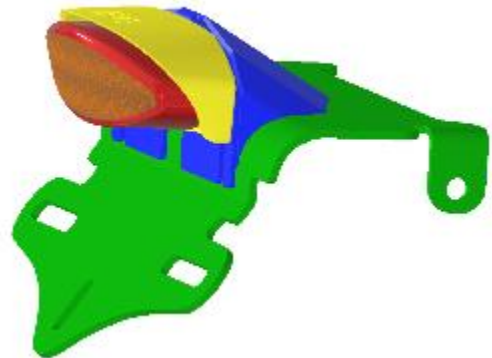

PHOTO 4

### **NOTICE DE MONTAGE**

- Enlevez les deux sièges.
- Déposer le capot de siège arrière.
- Débranchez le câblage de l'unité de plaque d'immatriculation d'origine.
- Desserrez les quatre boulons tenant l'unité de plaque d'immatriculation d'origine sur le sous-cadre.
- Retirez les clignotants d'origine et le feu arrière de l'unité de plaque d'immatriculation d'origine.
- L'unité de plaque d'origine doit comporter trois parties, à savoir; deux côtés et un support de plaque d'immatriculation.
- Replacez les deux assemblages latéraux sur le sous-cadre à l'aide des vis à tête ronde et des rondelles fournies (articles 3 et 4), tout en laissant les boulons desserrés.
- Montez les clignotants d'origine ou de votre choix (nous recommandons les micro-clignotants R&G - code produit RG370) sur les côtés d'origine.
- Montez le linceul (article 8) sur le nouveau feu arrière (article 9) voir la photo 1.
- Placez cet ensemble à travers les trous du support de la plaque d'immatriculation (article 1) comme indiqué sur la photo 2.
- Placez les écrous M3 et les rondelles sur les filets apparents comme indiqué sur la photo 2 (ne pas serrer à ce stade) et faites passer les fils dans le trou central.
- Protégez le fil avec une longueur de thermorétractable (article 10).
- Placez la plaque de protection (article 7) entre le carénage et le support, comme indiqué sur la photo 3, puis appuyez sur le support comme indiqué sur la photo 4 et serrez les écrous.
- Montez la nouvelle unité de support de plaque entre les panneaux latéraux.
- À l'aide de boulons à tête ronde plus courts et de rondelles plus petites fournies (articles 5 et 6), fixez le nouveau support de plaque sur les côtés d'origine en utilisant les écrous fournis (article 2).
- Faites passer le clignotant et le nouveau câblage du feu arrière à travers les clips fournis comme à l'origine.
- Rebranchez le câblage de clignotant en vérifiant son fonctionnement (Remarque: le clignotant droit dispose du connecteur ORANGE).
- À l'aide des connecteurs de bloc scotché fournis (article 11), reconnectez le câblage du feu arrière (nous suggérons de couper le connecteur de l'unité d'origine et de le raccorder à l'unité R&G) comme indiqué ci-dessous.

R&G

Unit 1, Shelley's Lane, East Worldham, Alton, Hampshire, GU34 3AQ

Tel: +44 (0)1420 89007 Fax: +44 (0)1420 87301 [www.rg-racing.com](http://www.rg-racing.com) Email: [info@rg-racing.com](mailto:info@rg-racing.com)



Nouveaux fils		Fils d'origine
Noir	au	Noir
Jaune	au	Noir/Blanc
Rouge	au	Noir/Jaune

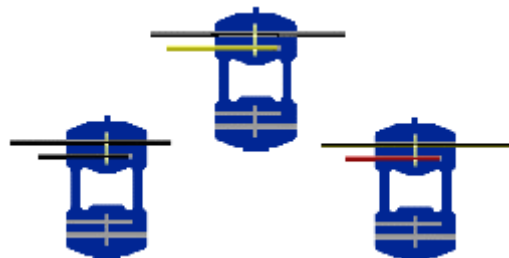

- **IMPORTANT : SI VOUS MONTEZ UNE PLAQUE DE GRANDE TAILLE ET QUE VOUS LA PLACEZ AU PLUS BAS DU SUPPORT DE PLAQUE, IL EST POSSIBLE QUE LA PLAQUE TOUCHE LA ROUE ARRIÈRE LORSQU'IL Y A UN POID IMPORTANT SUR LA ROUE ARRIÈRE OU LORSQUE VOUS ROULEZ SUR UNE GROSSE BOSSE. IL EST DE VOTRE RESPONSABILITÉ DE VÉRIFIER QUE CELA NE PUISSE SE PRODUIRE. NE PAS EFFECTUER CETTE VÉRIFICATION PEUT CONDUIRE À DES DOMMAGES POUR LA MOTO AINSI QUE POUR SON PILOTE OU SON PASSAGER.**
- Revérifier que les fils ne peuvent pas entrer en contact avec le silencieux d'échappement.
- Serrez tous les boulons de fixation du support au sous-cadre.
- Reposer le capot arrière.
- Reposer les sièges.
- Selon les lois locales, fixez le réflecteur fourni (article 12) à un endroit approprié.
- Testez les clignotants et le feu de plaque d'immatriculation avant de prendre la route.
- Veuillez tester les clignotants, le feu arrière et le feu de plaque d'immatriculation avant de prendre la route.

ISSUE 2 22/10/2019 (NSY)

R&G

Unit 1, Shelley's Lane, East Worldham, Alton, Hampshire, GU34 3AQ

Tel: +44 (0)1420 89007 Fax: +44 (0)1420 87301 [www.rg-racing.com](http://www.rg-racing.com) Email: [info@rg-racing.com](mailto:info@rg-racing.com)



**MONTAGEANLEITUNG FÜR LP0042BK KENNZEICHENHALTER  
FÜR HONDA CBR600 RR 2007-**



**ALLE KIT-TEILE SIND UNTEN GEKENNZEICHNET UND ABGEBILDET**

DIE ABGEBILDETEN TEILE DIENEN LEDIGLICH ZUR ERKLÄRUNG.

ÜBERPRÜFEN SIE ZUERST, DASS ALLE TEILE VORHANDEN SIND.

**LESEN SIE DIE MONTAGEANLEITUNG KOMPLETT DURCH, BEVOR SIE ANFANGEN.**

**WENN SIE BEI DER MONTAGE DIESES PRODUKTES UNSICHER SIND, BITTE EINEN  
UNSERER HÄNDLER KONTAKTIEREN ODER DAS KIT VON EINEM QUALIFIZIERTEN  
ZWEIRAD-MECHANIKER MONTIEREN LASSEN**

DIE VERPACKUNG DER TEILE STELLT NICHT DIE REIHENFOLGE DER MONTAGE DAR.

HINWEIS FÜR KITS MIT PLASTIKUNTERLEGSCHLEIBEN AN DEN SCHRAUBEN –

DIESE PLASTIK-UNTERLEGSCHLEIBEN WERDEN NICHT FÜR DEN EINBAU BENÖTIGT!

**EINE DIGITALE VERSION DIESER MONTAGEANLEITUNG KANN AUF  
FOLGENDER SEITE HERUNTERGELADEN WERDEN:**

[WWW.RG-RACING.COM](http://WWW.RG-RACING.COM)

R&G

Unit 1, Shelley's Lane, East Worldham, Alton, Hampshire, GU34 3AQ

Tel: +44 (0)1420 89007 Fax: +44 (0)1420 87301 [www.rg-racing.com](http://www.rg-racing.com) Email: [info@rg-racing.com](mailto:info@rg-racing.com)



<b><u>SIE BENÖTIGEN FOLGENDES WERKZEUG</u></b>	<b><u>ALLGEM. ANZUGSDREHMOMENT</u></b>
<ul style="list-style-type: none"> <li>• Satz Inbusschlüssel</li> <li>• Satz Steckschlüssel</li> <li>• Seitenschneider / Zange</li> </ul>	<p>M4 SCHRAUBE = 8Nm</p> <p>M5 SCHRAUBE = 12Nm</p> <p>M6 SCHRAUBE = 15Nm</p> <p>M8 SCHRAUBE = 20Nm</p> <p>M10 SCHRAUBE = 40Nm</p> <p>M12 SCHRAUBE = 40Nm</p>

### **LIEFERUMFANG**

<b>ARTIKEL-NR.</b>	<b>BESCHREIBUNG</b>	<b>MENGE</b>
ARTIKEL 1	KENNZEICHENHALTER (TB0042)	1
ARTIKEL 2	M6 SELBSTSICHERNDE MUTTER	2
ARTIKEL 3	M6 GROSSE UNTERLEGSCHIEBE	4
ARTIKEL 4	M6 x 20mm INBUSSCHRAUBE	4
ARTIKEL 5	M6 STANDARD UNTERLEGSCHIEBE	2
ARTIKEL 6	M6 x 15mm INBUSSCHRAUBE	2
ARTIKEL 7	ABDECKPLATTE (TB0042 TEIL 2)	1
ARTIKEL 8	LICHTABDECKUNG (LA0003 SHROUD)	1
ARTIKEL 9	RÜCKLICHT/KENNZEICHENBELEUCHTUNG	1
ARTIKEL 10	150mm SCHRUMPFSCHLAUCH	3
ARTIKEL 11	SCOTCH KABELVERBINDER	3
ARTIKEL 12	RÜCKSTRAHLER (REFL 3)	1

R&G

Unit 1, Shelley's Lane, East Worldham, Alton, Hampshire, GU34 3AQ

Tel: +44 (0)1420 89007 Fax: +44 (0)1420 87301 [www.rg-racing.com](http://www.rg-racing.com) Email: [info@rg-racing.com](mailto:info@rg-racing.com)



ABBILDUNG 1



ABBILDUNG 2

R&G

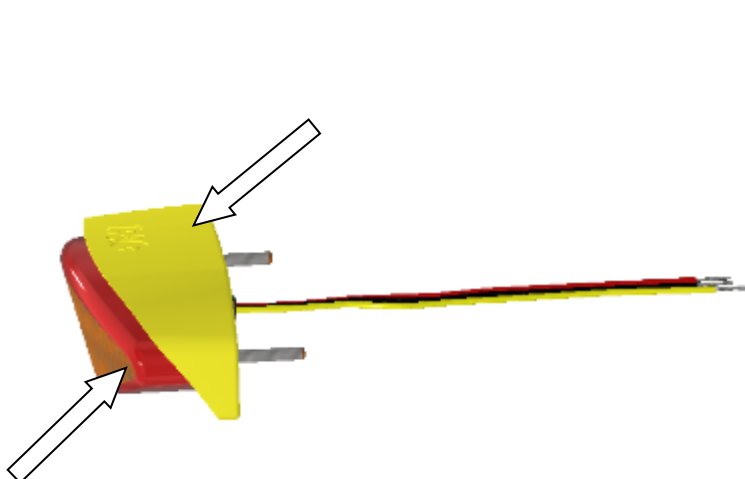
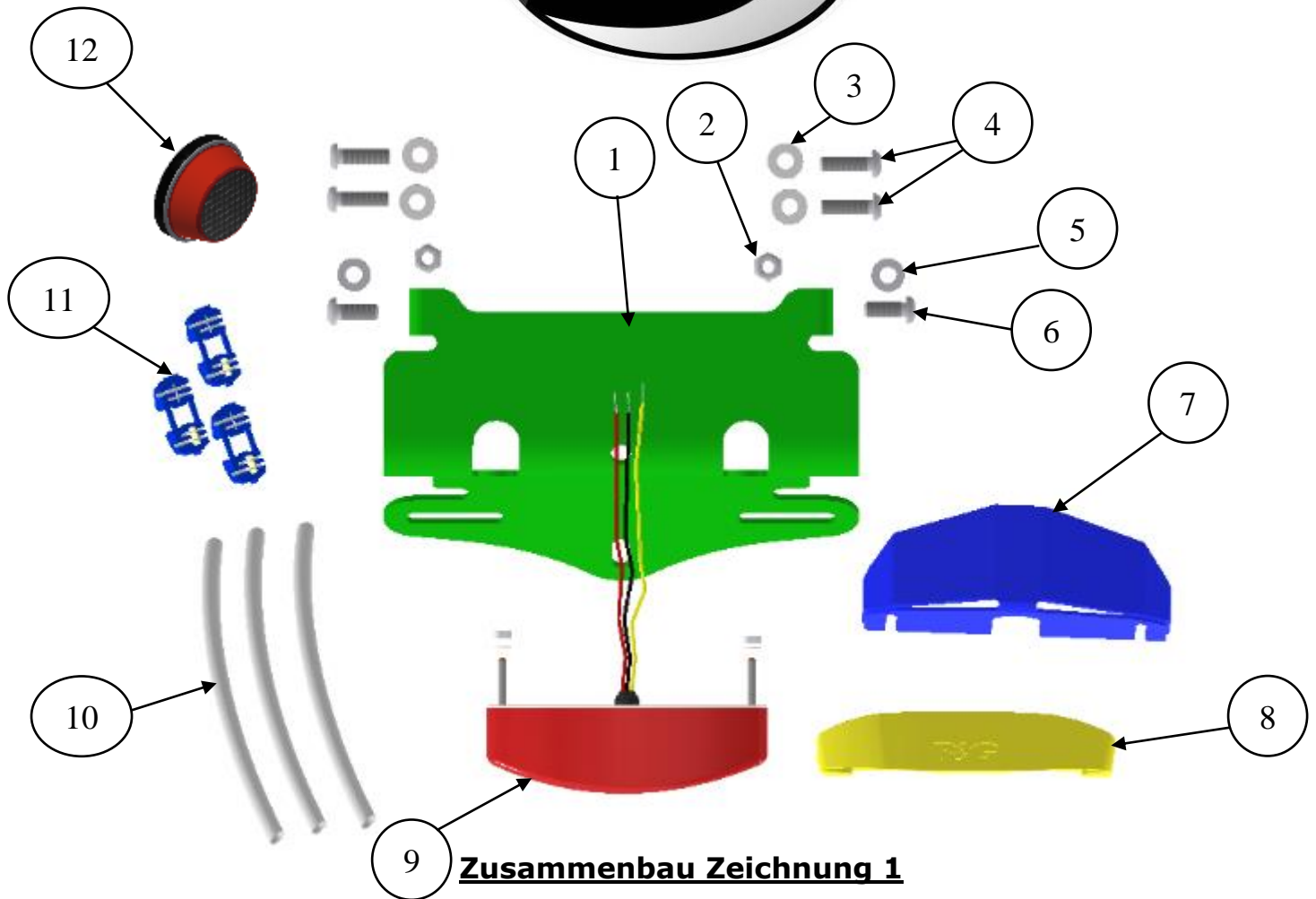
Unit 1, Shelley's Lane, East Worldham, Alton, Hampshire, GU34 3AQ

Tel: +44 (0)1420 89007 Fax: +44 (0)1420 87301 [www.rg-racing.com](http://www.rg-racing.com) Email: [info@rg-racing.com](mailto:info@rg-racing.com)

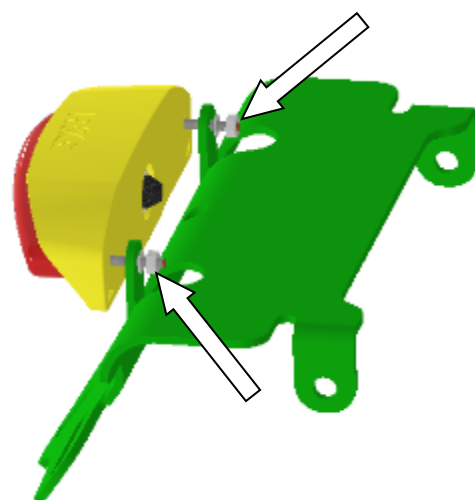

ABBILDUNG 3



ABBILDUNG 4

### **MONTAGEANLEITUNG**

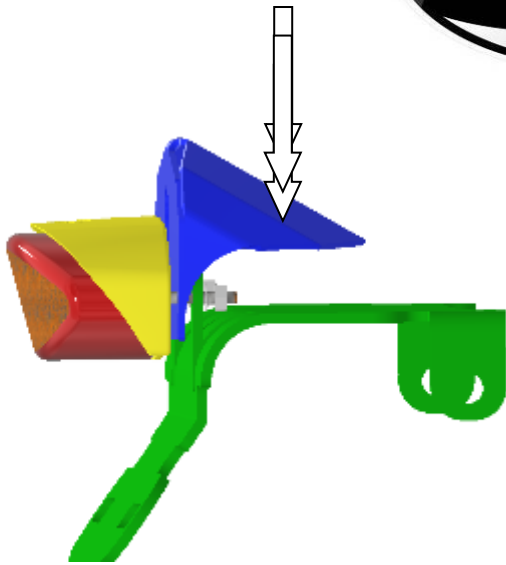
- Entfernen Sie beide Sitze.
- Entfernen Sie die hintere Sitzverkleidung.
- Trennen Sie die Kabel zum Originalkennzeichenhalter.
- Lösen Sie die vier Schrauben, die den original Kennzeichenhalter am Heckrahmen befestigen.
- Entfernen Sie die Originalblinker und die Rückbeleuchtungseinheit vom original Kennzeichenhalter.
- Der original Kennzeichenhalter sollte in drei Teilen sein d.h. zwei Seiten und eine Halterung für das Kennzeichen.
- Die beiden Seitenteile wieder am Heckrahmen fixieren – verwenden Sie hierfür die mitgelieferten Inbuschrauben und Unterlegscheiben (Artikel 3 und 4) aber die Schrauben noch nicht festziehen.
- Montieren Sie die Original- oder Zubehörblinker (wir empfehlen R&G Mini-Blinker, Artikel-Nr. RG370) an den Seitenteilen des original Kennzeichenhalters.
- Montieren Sie die Abdeckung (**Artikel 8**) an der neuen Rückbeleuchtung (**Artikel 9**) wie in **Abbildung 1** abgebildet.
- Die Einheit an den Öffnungen am Kennzeichenhalter (**Artikel 1**) montieren wie in **Abbildung 2** abgebildet.
- Die M3 Muttern und Unterlegscheiben an den hervorstehenden Gewinden anbringen wie in **Abbildung 2** abgebildet (zu diesem Zeitpunkt noch nicht festziehen) und die Kabel durch die mittlere Öffnung führen.
- Benutzen Sie eine Länge Schrumpfschlauch (Artikel 10), um die Kabel zu schützen.
- Die Abdeckplatte (Artikel 7) zwischen der Abdeckung und der Halterung positionieren wie in **Abbildung 3** abgebildet, zur Halterung runterdrücken wie in **Abbildung 4** abgebildet und die Muttern festziehen.
- Den neuen Kennzeichenhalter zwischen den Seitenteilen positionieren.
- Den neuen Kennzeichenhalter mit den kurzen Inbuschrauben und kleinen Unterlegscheiben (**Artikel 5 und 6**) sichern, und mit den selbstsichernden Muttern vom Kit (**Artikel 2**) an den original Seitenteilen befestigen.
- Die Kabel für die Blinker und die Rückbeleuchtung wie ursprünglich verlegt anbringen (verwenden Sie hierfür die mitgelieferten Clips).
- Verbinden Sie die Kabel für die Blinker, und überprüfen Sie ihre Funktion (Hinweis: der Steckverbinder für den rechten Blinker hat die Farbe ORANGE).
- Verwenden Sie die mitgelieferten Scotch Kabelverbinder (**Artikel 11**), um die Rückbeleuchtung wieder zu verbinden (wir empfehlen, den Originalsteckverbinder vom

R&amp;G

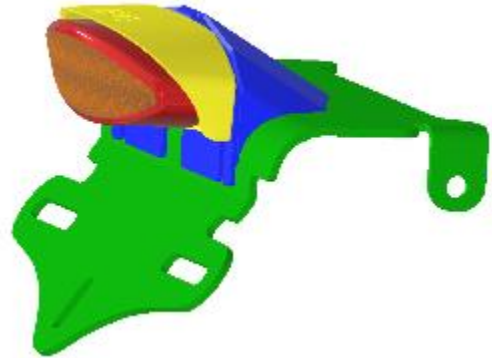
Unit 1, Shelley's Lane, East Worldham, Alton, Hampshire, GU34 3AQ

Tel: +44 (0)1420 89007 Fax: +44 (0)1420 87301 [www.rg-racing.com](http://www.rg-racing.com) Email: [info@rg-racing.com](mailto:info@rg-racing.com)



original Kennzeichenhalter abzutrennen und mittels Kabelverbinder mit der R&G Einheit zu verbinden) wie unten abgebildet:

Neues Kabel		Originalkabel
Schwarz	zu	Schwarz
Gelb	zu	Schwarz/Weiß
Rot	zu	Schwarz/Gelb

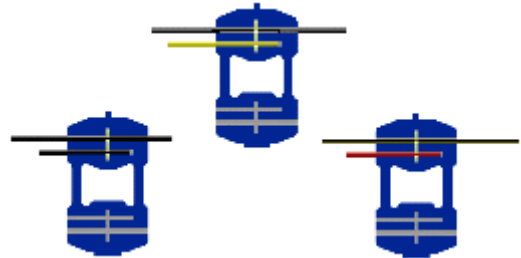

- **WICHTIG: WENN EIN GROSSES KENNZEICHEN ZU WEIT NACH UNTEN MONTIERT WIRD, BESTEHT BEI SCHWERER LAST ODER DURCH GROSSE BODENWELLEN EIN GERINGES RISIKO, DASS DAS KENNZEICHEN AN DAS HINTERRAD STOSSEN KANN. ES LIEGT IN IHRER VERANTWORTUNG DIES ZU ÜBERPRÜFEN UND, WENN NOTWENDIG, ZU VORBEUGENDEN MASSNAHMEN ZU ERGREIFEN. DIE NICHTBEACHTUNG DIESES SICHERHEITSHINWEISES KANN ZU SCHWEREN VERLETZUNGEN FÜHREN.**
- Überprüfen Sie, dass die Kabel den Auspuff-Schalldämpfer nicht berühren.
- Die Schrauben, die den Kennzeichenhalter am Heckrahmen befestigen nun festziehen.
- Montieren Sie die hintere Sitzverkleidung.
- Montieren Sie die Sitze.
- Entsprechend der gesetzlichen Vorschriften, den mitgelieferten Rückstrahler (**Artikel 12**) anbringen.
- Testen Sie die Funktion der Blinker und der Rückbeleuchtung vor Gebrauch des Fahrzeuges.
- **Überprüfen Sie die Funktion der kompletten Beleuchtung (Blinker und Kennzeichenhalter), bevor Sie mit dem Motorrad fahren.**

AUSGABE 2 22/10/2019 (NSY)

R&G

Unit 1, Shelley's Lane, East Worldham, Alton, Hampshire, GU34 3AQ

Tel: +44 (0)1420 89007 Fax: +44 (0)1420 87301 [www.rg-racing.com](http://www.rg-racing.com) Email: [info@rg-racing.com](mailto:info@rg-racing.com)