



**FITTING INSTRUCTIONS FOR BLP0107 FOOTREST BLANKING PLATE  
BMW S1000XR 2020-**



PICTURE A

**THIS KIT CONTAINS THE ITEMS PICTURED AND LABELLED OVER PAGE.**

DO NOT PROCEED UNTIL YOU ARE SURE ALL PARTS ARE PRESENT.

PLEASE READ ALL INSTRUCTIONS BEFORE PRECEEDING.

**IF IN ANY DOUBT WHEN FITTING OUR PRODUCTS, CONSULT ONE OF OUR DEALERS  
OR HAVE FITTED BY A QUALIFIED TECHNICIAN.**

PLEASE NOTE THAT THE WAY THE KIT IS PACKED DOES NOT NECESSARILY REPRESENT THE WAY OF  
MOUNTING TO THE BIKE.

THE PARTS SHOWN MAY BE REPRESENTATIVE ONLY (FOR CLARITY OF INSTRUCTIONS ONLY).

IN THE EVENT OF RUBBER WASHERS BEING USED TO HOLD COMPONENTS ONTO BOLTS,

THESE RUBBER WASHERS CAN BE THROWN AWAY.

**Digital copies of these instructions are available to download from  
[www.rg-racing.com](http://www.rg-racing.com)**

**TOOLS REQUIRED**

- Set of metric Allen keys to include 5mm.
  - Torx bits or keys.
  - Torque wrench to suit.

**MAXIMUM TORQUE SETTINGS**

- M4 BOLT = 8Nm
- M5 BOLT = 12Nm
- M6 BOLT = 15Nm
- M8 BOLT = 20Nm
- M10 BOLT = 40Nm
- M12 BOLT = 40Nm

**LEGEND**

ITEM No	DESCRIPTION	QTY
ITEM 1	BLANKING PLATE (BLPF0010)	1
ITEM 2	SPACERS (S0379)	2
ITEM 3	M8 x 20mm LONG COUNTER-SUNK BOLTS	2

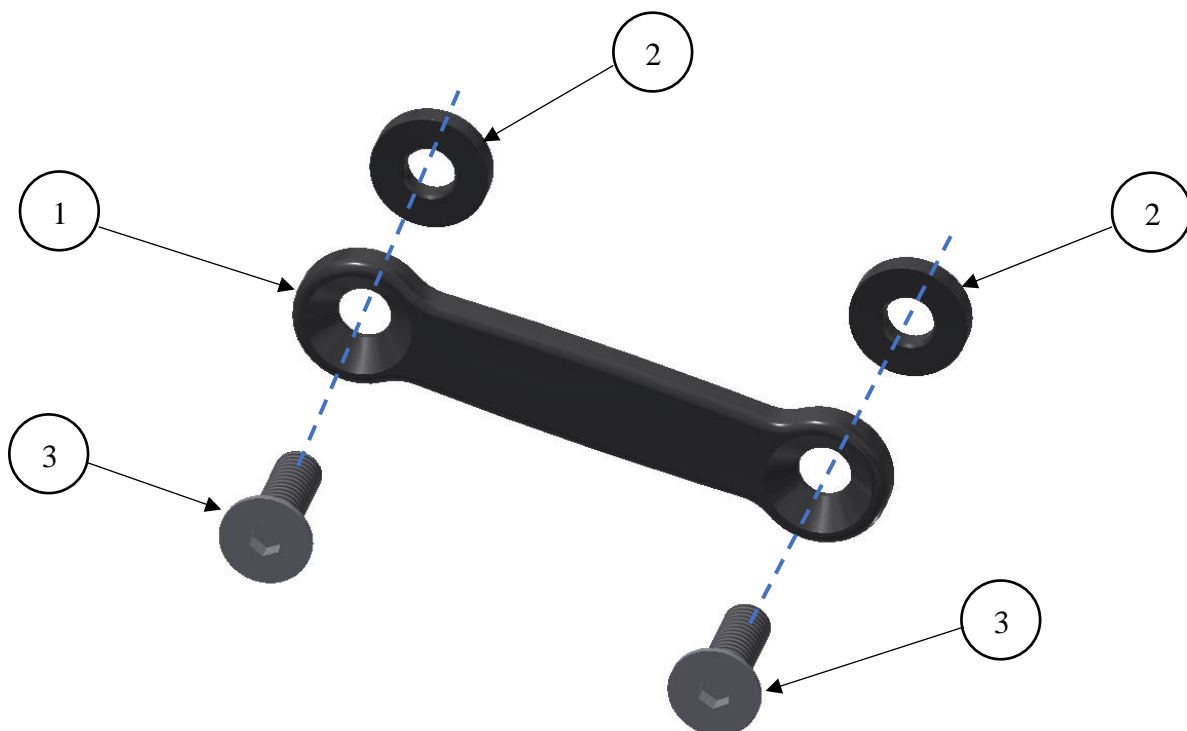
**ASSEMBLY**



PICTURE 1

### **FITTING INSTRUCTIONS**

- To fit the R&G Footrest Blanking Plate, the left hand side pillion footrest mounting bracket needs to be removed.
- To do this, remove the two mounting bolts at the top of the pillion footrest mounting bracket as arrowed in **picture 1**, then remove the OEM pillion footrest mount from the motorcycle.
- Take the R&G Blanking Plate (**item 1**) and fit the two M8 x 20mm long counter-sunk bolts (**items 3**) through the two counter-sunk holes of the blanking plate as shown in the **assembly picture**.
- Place the two spacers (**items 2**) over the exposed thread of both bolts as shown in the **assembly picture**.
- Offer this assembly into position and engage both bolts into the pillion foot peg mounting holes as shown in **picture A** and tighten to the recommended torque.
- Check the tightness of all bolts regularly.

Issue 1 26/10/2020 (NSY)

### **CONSUMER NOTICE**

The catalogue description and any exhibition of samples are only broad indications of the Products and R&G may make design changes which do not diminish their performance or visual appeal and supplying them in such state shall conform to the order. The Buyer acknowledges no representation or warranty (other than as to title) has been given or will apply to the Products other than those in R&G's order or confirmation and the Buyer confirms it has chosen the Products as being of merchantable quality and suitable for its particular purposes. Where R&G fits the Products or undertakes other services it shall exercise reasonable skill and care and rectify any fault free of charge unless the workmanship has been disturbed. The Buyer is responsible for ensuring that the warranty on the motorcycle is not affected by the fitting of the Products. On return of any defective Products R&G shall at its option either supply a replacement or refund the purchase money but shall not be liable if the Products have been modified or used or maintained otherwise than in accordance with R&G's or manufacturer's instructions and good engineering practice or if the defect arises from accident or neglect. Other than identified above and subject to R&G not limiting its liability for causing death and personal injury, it shall not be liable for indirect or consequential loss and otherwise its liability shall be limited to the amounts paid by the Buyer for the Products or the fitting or service concerned. These terms do not affect the Buyer's statutory rights.

### **R&G RETURNS POLICY (NON-FAULTY GOODS)**

Returns must be pre-authorized (if not pre-authorized the return will be rejected). Goods may only be returned direct to us if they were purchased direct from us (customer must prove if necessary). Otherwise to be returned to original vendor. Goods must be in re-sellable condition, in the opinion of R&G. All returns are subject to a 25% restocking and handling fee (25% of the gross value exc. P&P – at the prevailing price at time of purchase). The customer must pay any and all carriage charges. No returns of discontinued products, unless within 14 days of purchase. This policy does not affect your statutory rights and does not refer to faulty goods.

R&G Racing

Unit 1, Shelley's Lane, East Worldham, Alton, Hampshire, GU34 3AQ

Tel: +44 (0)1420 89007 Fax: +44 (0)1420 87301 [www.rg-racing.com](http://www.rg-racing.com) Email: [info@rg-racing.com](mailto:info@rg-racing.com)



**NOTICE DE MONTAGE POUR BLP0107**  
**PLAQUE D'OBTURATION DE REPOSE PIED**  
**BMW S1000XR 2020-**



PHOTO A

**CE KIT CONTIENT LES ARTICLES ILLUSTRÉS ET ÉTIQUETES SUR LA PAGE.**

CERTAINES PARTIES PEUVENT ÊTRE PRÉSENTES UNIQUEMENT POUR LA CLARTE DES INSTRUCTIONS.

NE PAS PROCÉDER AU MONTAGE TANT QUE VOUS N'ÊTES PAS SÛR QUE TOUTES LES PIÈCES SOIENT PRÉSENTES.

**VEUILLEZ LIRE TOUTES LES INSTRUCTIONS AVANT DE CONTINUER.**

**EN CAS DE DOUTE LORS DU MONTAGE DE NOS PRODUITS, CONSULTEZ UN DE NOS REVENDEURS OU FAITES APPEL À UN TECHNICIEN QUALIFIÉ.**

VEUILLEZ NOTER QUE LA FAÇON DONT LE KIT EST EMBALLÉ NE REPRÉSENTE PAS NECESSAIREMENT LA MANIÈRE DE LE MONTER SUR LA MOTO.

SI DES RONDELLES EN CAOUTCHOUC SONT UTILISÉES POUR MAINTENIR LES COMPOSANTS SUR LES BOULONS, ELLES PEUVENT ÊTRE JETÉES.

**NOTICE DISPONIBLE AU TÉLÉCHARGEMENT SUR : [WWW.RG-RACING.COM](http://WWW.RG-RACING.COM)**

**OUTILS REQUIS**

- Clés Allen 5mm.
- Clés Torx.
- Clé dynamométrique to suit.

**VALEURS DE SERRAGE RECOMMANDÉES**

- M4 BOULON = 8Nm
- M5 BOULON = 12Nm
- M6 BOULON = 15Nm
- M8 BOULON = 20Nm
- M10 BOULON = 40Nm
- M12 BOULON = 40Nm

**LÉGENDE**

ARTICLE No	DESCRIPTION	QTÉ
ARTICLE 1	PLAQUE D'OBTURATION (BLPF0010)	1
ARTICLE 2	ENTRETOISES (S0379)	2
ARTICLE 3	M8 x 20mm BOULONS	2

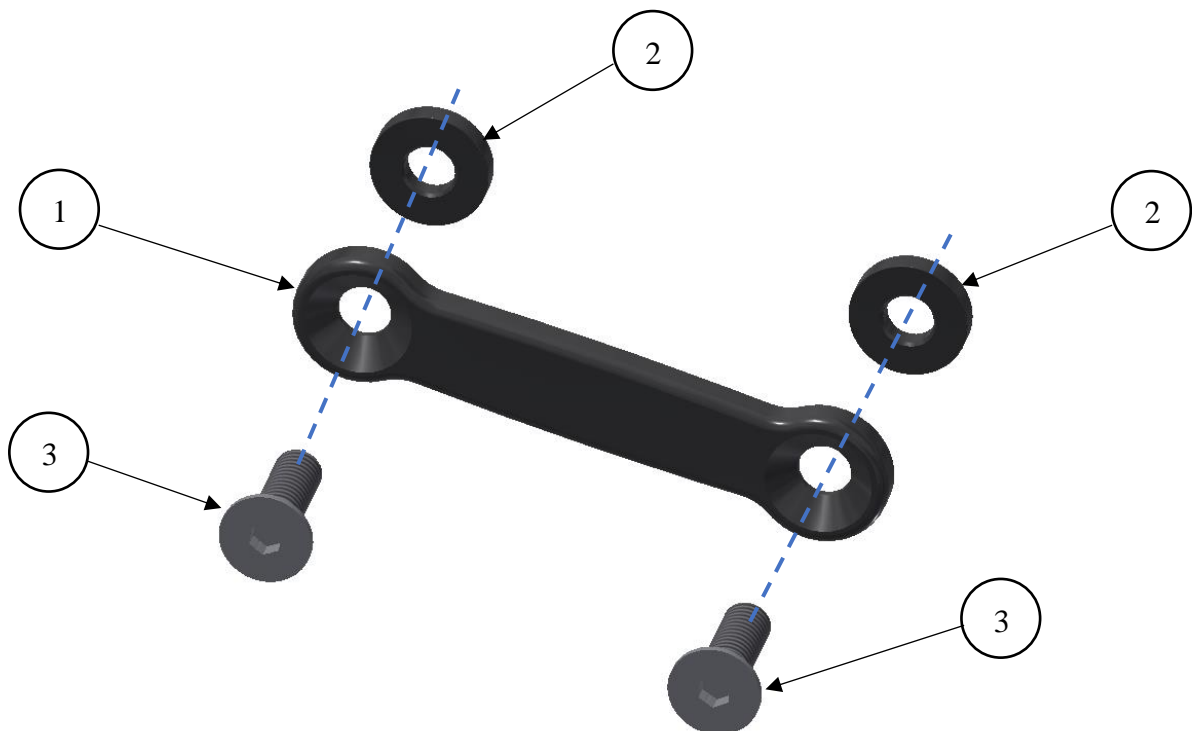
**ASSEMBLAGE**

R&amp;G Racing

Unit 1, Shelley's Lane, East Worldham, Alton, Hampshire, GU34 3AQ

Tel: +44 (0)1420 89007 Fax: +44 (0)1420 87301 [www.rg-racing.com](http://www.rg-racing.com) Email: [info@rg-racing.com](mailto:info@rg-racing.com)



PHOTO 1

### **NOTICE DE MONTAGE**

- Pour installer la plaque d'obturation du repose-pied R&G, le support de montage du repose-pied passager gauche doit être retiré.
- Pour ce faire, retirez les deux boulons de montage en haut du support de montage du repose-pied passager comme indiqué sur la flèche sur la photo 1, puis retirez le support du repose-pied passager d'origine de la moto.
- Prenez la plaque d'obturation R&G (article 1) et insérez les deux boulons M8 x 20 mm de long (articles 3) à travers les deux trous de la plaque d'obturation comme indiqué sur la photo d'assemblage.
- Placez les deux entretoises (articles 2) sur le filetage exposé des deux boulons comme indiqué sur la photo d'assemblage.
- Mettez cet assemblage en place et engagez les deux boulons dans les trous de montage des repose-pieds du passager comme indiqué sur la photo A et serrez au couple recommandé.
- Vérifiez régulièrement le serrage de tous les boulons

Issue 1 26/10/2020 (NSY)